

Point Machine Coupler

Reduced installation and testing times for new or serviced point machines

Network Rail – Certificate Number PA05/297



This product ensures:

- **Reliability:**
Secure and waterproof junction.
- **Safety:**
Impossible to terminate incorrectly.
- **Quick installation/replacement**
Reduced possession requirement.
- **Simple point machine termination:**
Polarised termination with locating marker.
- **100% correct termination:**
All assemblies 100% factory tested.

To meet the continual drive for improvements to track-side electrical connections, Unipart Rail and Prysmium supply a modular connect/disconnect system for point machines which has full Network Rail approval.

Contact for technical advice

Telephone: +44 (0) 1270 847708

Facsimile: +44 (0) 1270 847721

e-mail: technicalsupport@unipartrail.com

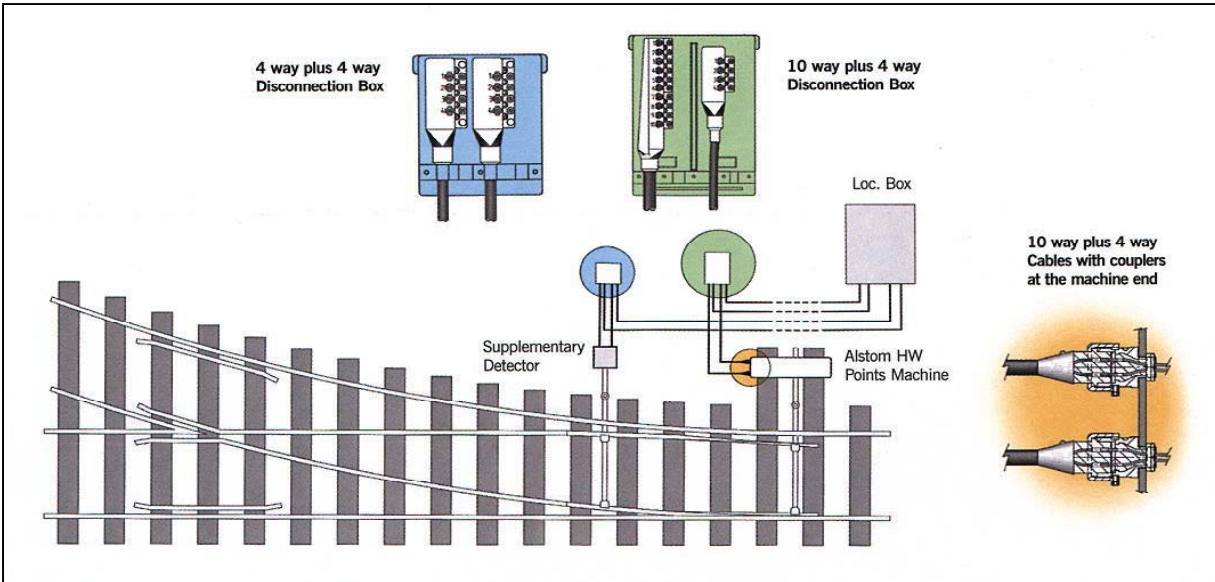

Item		Rail Industry Catalogue No
4 Way Plug Coupler:	1m Tails	88/000500
10 Way Plug Coupler:	1m Tails	88/000501
4 Way plus 4 Way Disconnection Box		88/000502
10 Way plus 4 Way Disconnection Box		88/000503
4 Way Socket Coupler and Free End:	5m Cable	88/000504
	10m Cable	88/000505
	15m Cable	88/000506
	20m Cable	88/000507
10 Way Socket Coupler and Free End:	5m Cable	88/000508
	10m Cable	88/000509
	15m Cable	88/000510
	20m Cable	88/000511
4 Way Moulded Termination and Free End:	5m Cable	88/000512
	10m Cable	88/000513
	15m Cable	88/000514
	20m Cable	88/000515
10 Way Moulded Termination and Free End:	5m Cable	88/000516
	10m Cable	88/000517
	15m Cable	88/000518
	20m Cable	88/000519
4 Way Socket Coupler with 4 Way Moulded Termination:	5m Cable	88/000520
	10m Cable	88/000521
	15m Cable	88/000522
	20m Cable	88/000523
10 Way Socket Coupler with 10 Way Moulded Termination:	5m Cable	88/000524
	10m Cable	88/000525
	15m Cable	88/000526
	20m Cable	88/000527
Other cable lengths can be manufactured to order.		

The versatility of the system offers solutions to all possible track layouts.

The system comprises the following items, not all items are required for all installations -

- 4-way plug and 10-way plug with 1m tails for point machines (new and retro fit)
- 10-way socket to 10-way pre-terminated end with 5m, 10m, 15m or 20m cable
- 4-way socket to 4-way pre-terminated end with 5m, 10m, 15m or 20m cable
- 10-way socket to un-terminated end with 5m, 10m, 15m or 20m cable
- 4-way socket to un-terminated end with 5m or 10m of cable
- 10-way pre-terminated end to un-terminated end with 5m, 10m, 15m or 20m cable
- 4-way pre-terminated end to un-terminated end with 5m, 10m, 15m or 20m cable
- 2 x 4-way disconnection box
- 10 and 4-way disconnection box
- Cables can also be supplied to customer specified lengths

Available from:

Unipart Rail, Leeman Road, York, Yorkshire, YO26 4ZD, UK

T +44 (0) 1904 544020 **F** +44 (0) 1904 544021