

# Cable Clips for Points

## Heating & Signalling

Britclips RHC fixings are easily and rapidly installed simply by hammering onto the foot of the rail. Once in place, they powerfully resist the effects of movement and vibration and cope extremely well with corrosive environments.

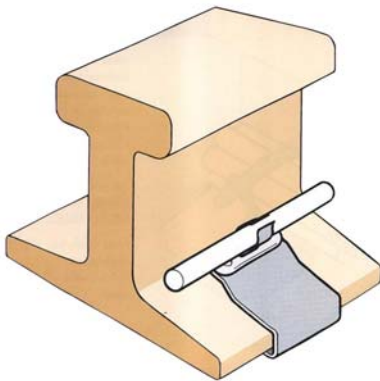

Cat N° 0055/009162

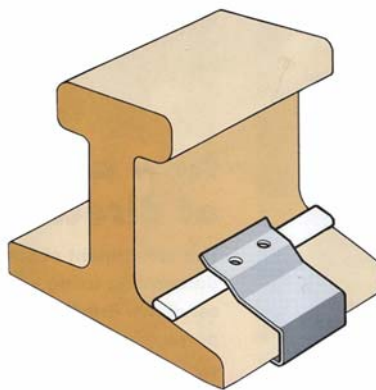

Cat N° 0055/009169

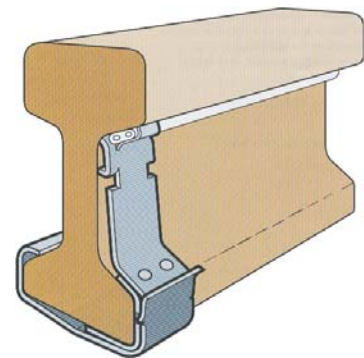

Cat N° 0055/009156

For a full range of clips, see overleaf

- Robust and vibration resistant
- Resistant to corrosive environments
- Quick and simple to install using a hammer
- Specially up-tilted leading edge that enables the clip to rise up and over the heating element as it is being installed
- Completely secure once installed

Network Rail Certificate N<sup>os</sup> PA05/456 and PA05/993

**Britclips**

**Contact for technical advice**

Telephone: +44 (0) 1270 847708

Facsimile: +44 (0) 1270 847721

e-mail: [technicalsupport@unipartrail.com](mailto:technicalsupport@unipartrail.com)

**UNIPART**  
**RAIL**

Product Bulletin No 254

Catalogue N°	Application	Rail Type
0055/009155	To fit heater to foot	BSI 10,BSI 13A, UIC60
0055/009156	To fit heater to foot	UIC54A
0055/009157	To fit heater to foot	UIC54B
0055/009158	To fit heater barrel	BSI 10,BSI 13,UIC 60
0055/009159	To fit heater barrel	UIC54A
0055/009160	To fit heater barrel	UIC54B
0055/009161	To fit heater under head	BSI 10, BSI 13
0055/009166	To fit heater to foot	UIC60B
0055/009167	To fit heater barrel	UIC60B
0055/009162	single cable run 13 -15mm diameter	BSI 10,BSI 13,UIC60
0055/009163	single cable run 19 -21mm diameter	BSI 10,BSI 13,UIC60
0055/009164	single cable run 24 -27mm diameter	BSI 10,BSI 13,UIC60
0055/009165	single or multiple cable runs Max. cable tie: 9.5mm wide x 2.5mm deep.	BSI 10,BSI 13, UIC60
0055/009175	To fit temperature control sensor	BSI 13,UIC 60
0055/009168	To fit heater to foot	Bullhead 95R
0055/009169	To fit heater under head	Bullhead 95R
0055/009172	To fit heater barrel	Bullhead 95R
PENDING	To fit heater to foot of rail at toe end	Bullhead 95R

Available from:

**Unipart Rail**, Gresty Road, Crewe, Cheshire, CW2 6EH, UK

**T** +44 (0) 1270 847 600 **F** +44 (0) 1270 847601