

# E-Clip De-Clipper

The fastest and safest solution for removing Pandrol clips



Remove clips at up to 2.5 miles of track per hour  
Simple, safe, efficient and proven technology  
Automatic system to prevent sleeper damage  
Fully approved by Network Rail



# The EDCI5 E-Clip De-Clipper is the fastest and safest solution for removing Pandrol PR and E-clips in re-railing and re-laying operations.

Simple to use, safe, fast and proven on the rail infrastructure, the E-Clip De-Clipper can remove clips from one or two rails at up to 2.5 miles of track per hour.

The clips are removed by spring loaded hooks carefully set to apply enough force to remove tough clips without risk of breaking sleepers (ties). Clips drop safely onto the ballast close to the housings for easy replacement.

If the machine encounters clips that are badly corroded, it automatically jumps over the clip. This protects the sleepers from damage where clips are very badly corroded.



## Features and Benefits

- Remove up to 2.5 miles of clips per hour
- Reduced manpower, increased safety
- Adjustable for rail height and wear
- Twin hydraulic circuit - de-clip one rail or both
- Heavy duty construction
- Built-In Pressure Control
- Rubber baffles to prevent clips flying
- Full range of adapter heads including tilting heads
- Full Factory Parts Backup
- CE Marked



## Technical Specifications

Specification	
Tare Weight	2,050 kg (4,510lbs)
Adapter Head	Full Range Available
Max. Operating Speed	8 kph (5 mph)
Operation	2 Pass 1 Rail / 2 Rail
Design Gauge	W6A
Hydraulic System	Twin Circuit
Maximum Inlet Pressure	350 Bar (5,000 psi)
Minimum Inlet Pressure	90 Bar (1,300 psi)

Construction	
Frame	All-steel fully welded
De-Clipping Hooks	Work Hardening Steel
Wheel Bearings	Rubber Sealed Ball Race
Pipework	12mm steel
Hoses	3/8" BSP
Burst Protection	Pilot Operated Check Valves
Pressure Reducing Valve	Aluminium body
Optional Extras	Interchangeable Heads

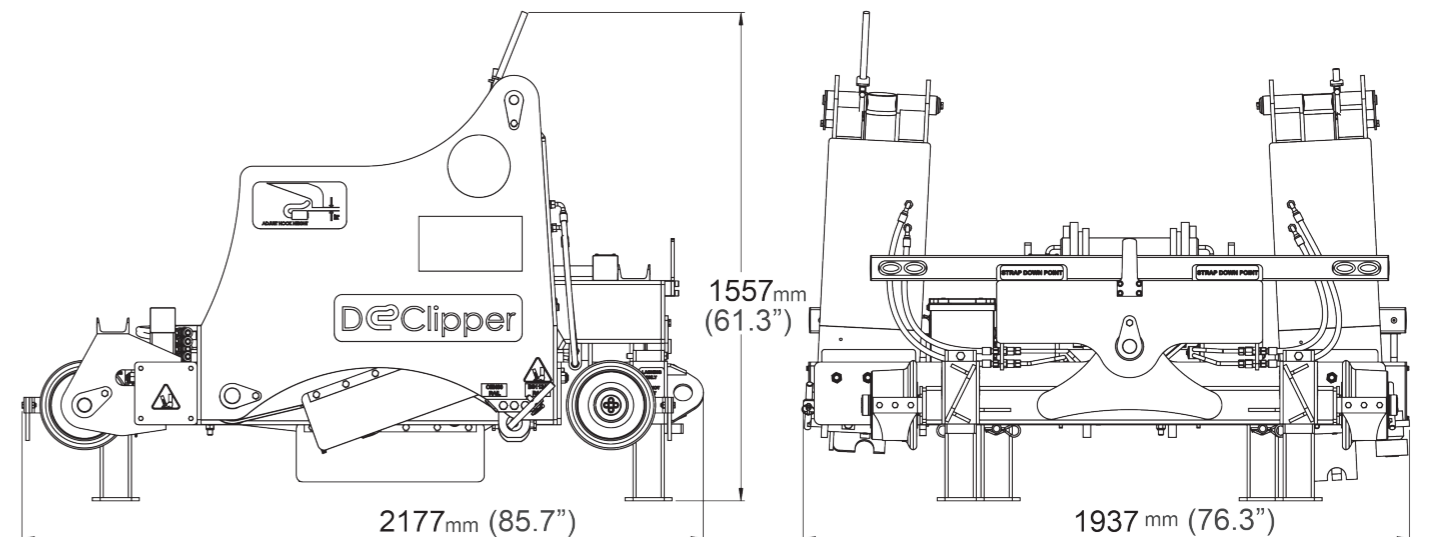

**Powerful, safe, efficient and built to last - the E-Clip De-Clipper is the most efficient solution available for Pandrol clip removal.**

For enquiries and orders, please contact [railplant@unipartrail.com](mailto:railplant@unipartrail.com) with catalogue number 0094/021254.



## About Unipart

The Unipart Group is a leading UK manufacturer, full service logistics provider and consultant in operational excellence.

Operating across a range of market sectors, including automotive, manufacturing, mobile telecoms, rail, retail and technology, Unipart offers a breadth of services to a wide range of blue chip clients internationally.

## About Thomson Engineering Design

Thomson Engineering Design has been manufacturing specialised equipment for rail renewals and repairs since 1999 and in that time have become the premier supplier of attachments for Road Rail Vehicles.

Offering a range of over 100 products for all rail maintenance sectors and activities, Thomson are a key supplier for all rail plant companies in the UK.



Unipart Rail are the export distribution partner for Thomson Engineering Design, for enquiries please contact [railplant@unipartrail.com](mailto:railplant@unipartrail.com)

### Unipart Rail

Jupiter Building, First Point, Balby Carr Bank,  
Doncaster DN4 5JQ

Tel: +44 (0) 1302 731400

email: [enquiries@unipartrail.com](mailto:enquiries@unipartrail.com)



Visit [www.unipartrail.com](http://www.unipartrail.com) for details  
of our Worldwide Regional Offices