

Thomson Engineering Design Product Catalogue

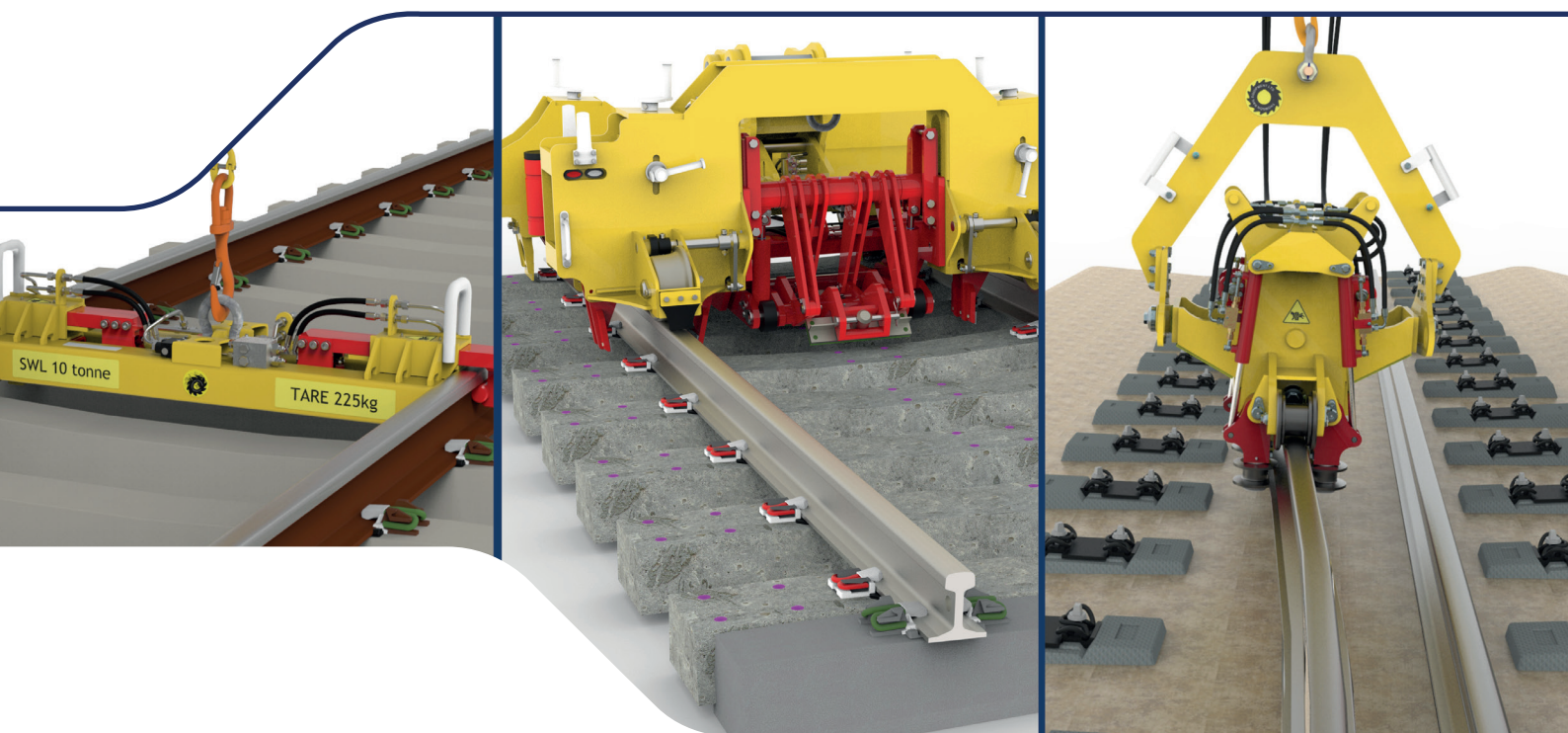

Specialised machines, attachments and tools for railway maintenance, designed and manufactured to ensure quality, reliability and safety.

UNIPART
RAIL



**THOMSON
ENGINEERING
DESIGN**

Durable, Reliable and Safe

SERVING THE WORLD'S RAILWAYS

CONTENTS

Section 1: Rail Handling	3	Section 7: Cable and Electrification	83
<i>Rail Storage Racks</i>	4	<i>Cable Handling Yoke</i>	84
<i>Drag Clamp</i>	6	<i>Dual Cable Handling Yoke</i>	86
<i>Autolok Rail Grab</i>	8	<i>Cable Thimbles</i>	88
<i>RLB20 Rail Beam</i>	10	<i>Steel Section Manipulator</i>	90
<i>RT211 Cuttlefish Rail Turner</i>	12	<i>Tube Pile Handler</i>	92
<i>Universal Lifting Beam</i>	14	<i>Stovepipe Lifter</i>	94
<i>TRLB20 Telescopic Rail Lifting Beam</i>	16	<i>Delivery Stillages</i>	96
<i>Universal Rail Thimble</i>	18		
<i>Threader Dragger</i>	20	Section 8: Miscellaneous Equipment	99
<i>Rail Foot Thimble</i>	22	<i>Elk Trolley Skate</i>	100
<i>Multi-Rail Handler</i>	24	<i>Rail Marking / Greasing Trolley</i>	102
<i>Rail Handling Beam</i>	26	<i>Tow Bars, Links and Adapters</i>	104
		<i>Lightweight Roller Beds</i>	106
Section 2: Sleeper Handling	29		
<i>Sleeper Handler</i>	30	Section 9: Barriers and Access	109
<i>Sleeper Manipulator</i>	32	<i>Instant Barrier System</i>	110
<i>Sleeper Spreader Beams</i>	34	<i>Traxess Road Rail Access Platform</i>	112
<i>Concrete Sleeper Pack Grab</i>	36	<i>Track Access Ramps</i>	114
<i>Plate Grab</i>	38		
<i>TCSG16 Sleeper Grab</i>	40	Section 10: Adapter Heads	117
		<i>Heads for Hooks</i>	120
Section 3: Panel Handling	43	<i>Single Pin Rotator Heads</i>	122
<i>Universal Lifting Beam</i>	44	<i>Two-Pin Rotator Heads</i>	124
<i>Low Headroom Panel Beam</i>	46	<i>Archimedes Adapter Heads</i>	126
<i>Small Panel Handler</i>	48	<i>Adapter Heads for Truck Cranes</i>	128
<i>Heavy Panel Handler</i>	50	<i>Special Adapter Heads</i>	130
<i>Panel Lifting Hook Beam</i>	52		
<i>Gantry Crane Panel Beam</i>	54		
		PRODUCTS FOR ROAD HAULAGE	
Section 4: Ballast and Trackbed	57	<i>Autolok Rail Grab</i>	8
<i>Geotextile Handler</i>	58	<i>TRLB20 Telescopic Rail Lifting Beam</i>	16
<i>Bag Holder</i>	60	<i>Rail Handling Beam</i>	26
<i>Bag Handling Forks</i>	62	<i>Sleeper Handler</i>	30
<i>Bag Carrier</i>	64	<i>Plate Grab</i>	38
<i>Multi Bag Carrier</i>	66	<i>TCSG16 Sleeper Grab</i>	40
		<i>Bag Carrier</i>	64
Section 5: Clipping and De-Clipping	69	<i>Multi Bag Carrier</i>	66
<i>Mk3 Fastclip Attachment</i>	70	<i>Cable Handling Yoke</i>	84
<i>E-Clip De-Clipper</i>	72	<i>Tube Pile Handler</i>	92
		<i>Delivery Stillages</i>	96
Section 6: Signals and Crossings	75		
<i>Signal Post Grab</i>	76		
<i>Signal Post Crane</i>	78		
<i>Crossing Slab Lifter</i>	80		

Section 1: Rail Handling

1.1 RSR11 RAIL STORAGE RACKS

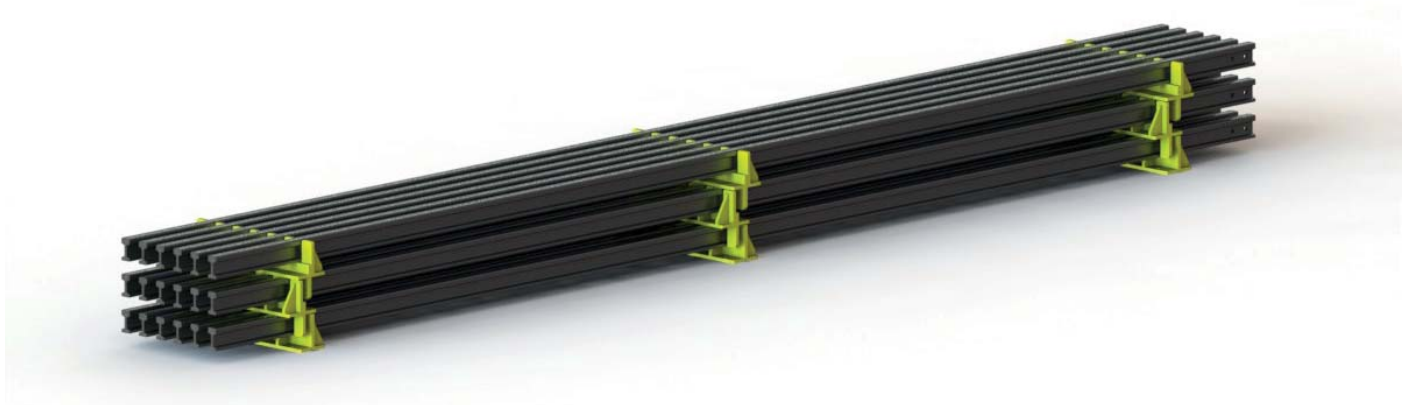

Safely stacking rails, particularly bullhead section rail, is a simple matter with Thomson Rail Storage Racks.

The system consists of two rack types: the Base Rack rests on the ground and carries the first layer of rails, the Layer Rack allows further layers to be stacked on top.

The maximum height of a stack of rails depends upon the ground conditions but, as well as maximising space, our Rail Storage Racks provide a neat, safe solution.

Racks are available for all rail types including conductor rail and can be made to carry up to 15 rails per layer.

SPECIFICATIONS

Weight (Bullhead Base 6-rail) 25 kg
 Weight*(Bullhead Layer 6-rail) 24.5 kg
 Max. Stack height depends on ground conditions.

*All layer racks fitted with central lifting point

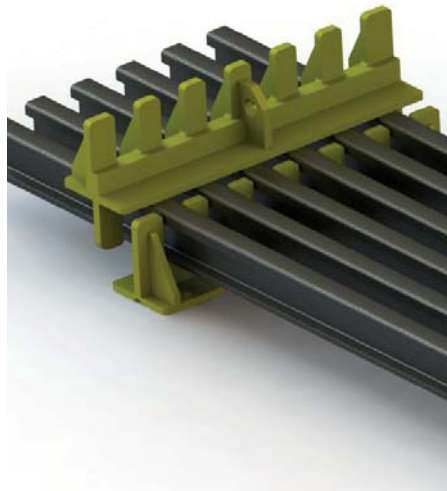

Body Colour 08E51 Yellow

FEATURES

- Lightweight & Compact
- Neat & Tidy Solution
- 6-Rail Racks manually handleable
- Racks available for any width
- Racks available for all rail types
- High Strength
- All Steel Construction
- Rails held at suitable spacing for grab handling
- High Resistance to abuse
- Powder coated finish
- CE Marked

A ROBUST, SAFE AND SECURE SYSTEM FOR STACKING AND STORING RAIL SECTIONS

DOCUMENTATION

- User Manual
- Installation Drawing
- Factory Inspection Certificate

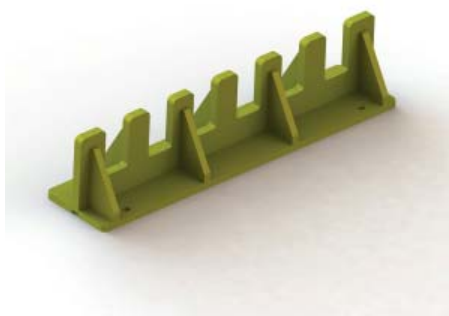

BENEFITS

- Simple and Safe
- Compatible with Thomson Rail Handling Devices
- Space Saving

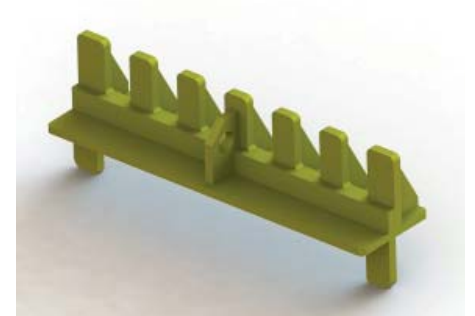

Specifications given may be subject to change due to our policy of continuous improvement

OPTIONS AND ORDERING INFORMATION

Thomson RSR11 Rail Storage Racks can be made to suit almost any number of rails and to suit either bullhead or flat bottom rail types.

The Base Rack has anchor bolt holes for M16 bolts (number and location vary with rack size).

Racks are supplied with a design conformity certificate.

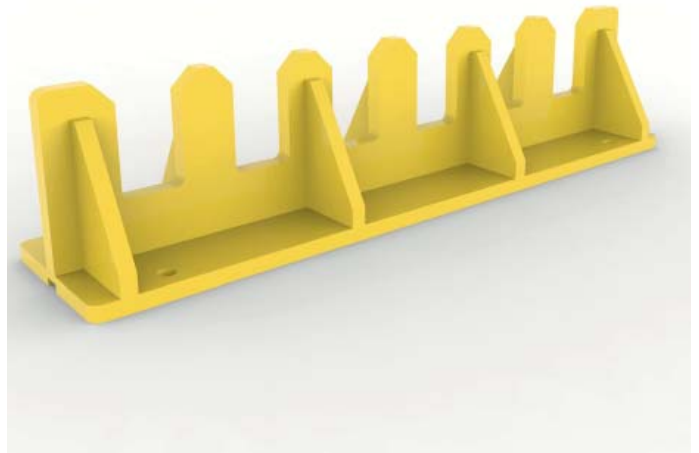

Example: RSR11-01-06 Base Rack for 6 bullhead rails

PRODUCT ACCEPTANCE

Rail Storage Racks are not intended for use on Network Rail infrastructure and no application has been made for Product Acceptance

MODEL NUMBERS FOR ORDERING

When ordering a Rail Storage Rack the order code specifies the various options.

RSR11-□□-□□

Rack Type	Code
<i>Bullhead Rail Base</i>	01
<i>Bullhead Rail Layer</i>	02
<i>Flat Bottom Rail Base</i>	03
<i>Flat Bottom Rail Layer</i>	04

No of Rails per Layer	Code
<i>1 rail</i>	01
<i>2 rails</i>	02

Max 15

1.2 DC06 DRAG CLAMP



The Thomson Drag Clamp has a unique cam action rail gripping system which tightens its grip on the rail the harder you pull.

Massive, all-steel construction ensures that the Thomson Drag Clamp is tough enough for the job.

Large bearing areas and soft surfaces where the drag clamp grips the rail prevent damage to the rail in use.

The cam surfaces can be rotated six times to give a very long life indeed.



FEATURES

- Lightweight & Compact
- Cam Mechanism
- Can be supplied with chain
- High Strength
- All Steel Construction
- High Resistance to Dynamic Loads
- High Resistance to Abuse
- Proven in Use Since 2007
- 10,000 kg Max. Tow Load
- Fits CEN60 and BS113 Rail
- Full Factory Parts Backup
- CE Marked

A ROBUST, EASY TO USE DRAG CLAMP, SMALL ENOUGH TO FIT THE TOOLBOX OF MOST RRV's

SPECIFICATIONS

Weight	45 kg
Rated Pull	10,000 kgf
Proof Load (Factory test)	20,000 kgf
Mechanism	Cam type
Construction	Rigid All Steel
Body Colour	08E51 Yellow

OPTIONS

Can be supplied with tow chain and / or shear link

DOCUMENTATION

Operator's Manual
Parts Manual
Maintenance Plan
Factory Test Certificate

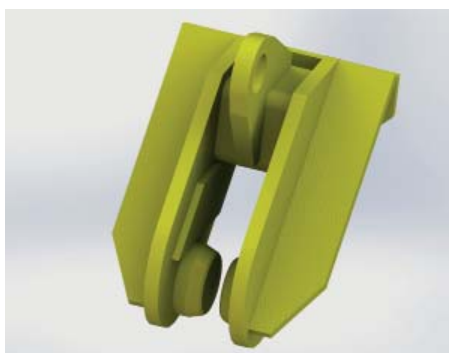

BENEFITS

- Cam mechanism means no linkage to jam
- Secure grip on rail
- No moving parts to jam or fail



Specifications given may be subject to change due to our policy of continuous improvement

OPTIONS AND ORDERING INFORMATION

The DC06 Drag Clamp is available with or without a tow chain.

This device is suitable for BS113 and CEN60 flat bottom rails.

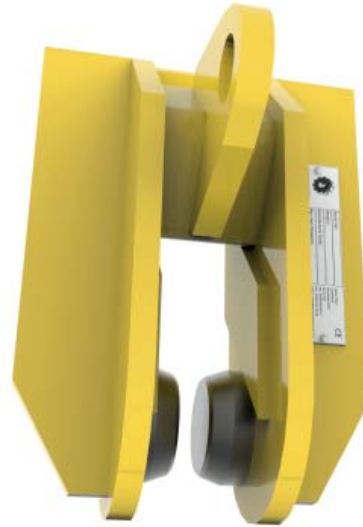

PRODUCT ACCEPTANCE

In 2006 when this product came onto the market Product Acceptance was not required for 'loose lifting and handling equipment'. No Product Acceptance application has been made for this product.

Example: DC06-01 Drag Clamp only

MODEL NUMBERS FOR ORDERING

When ordering a DC06 Drag Clamp please use the ordering code below:

DC06-□□

Drag Clamp Type	Code
<i>Drag Clamp Only</i>	01
<i>With Tow Chain</i>	02
<i>With Tow Chain & Shear Link</i>	03

1.3 ARG08 AUTOLOK RAIL GRAB



The Autolok Rail Grab has been specifically designed for use with excavators and hydraulic cranes and is built to stand the high dynamic loads which these machines can produce.

Whichever model you choose the Autolok can be supplied for use in handling running rails, grooved rails and conductor rails as required.

A key feature of the Autolok Rail Clamp is the fully enclosed mechanism with a 'red flag' indicator to tell the operator when the device is safely locked onto the rail.

Although the Autolok weighs just 25kg it has a Safe Working Load of 2,000 kg and is tested to 4 tonnes.

SPECIFICATIONS

Weight (Autolok H)	25 kg
Weight (Autolok M)	24.5 kg
WLL (Safe Working Load)	2,000 kg
Proof Load (Factory test)	4,000 kg
Mechanism	Cam Operated
Indication	'Red Flag' Indicator
O/A Height	575 mm
O/A Width	140mm
O/A Length	230 mm



FEATURES

- Lightweight & Compact
- Cam Mechanism
- Hydraulic or Manual Operation
- High Strength
- All Steel Construction
- High Resistance to Dynamic Loads
- High Resistance to Abuse
- Proven in Use Since 2006
- 2,000 kg WLL
- 4,000 kg Proof Load
- Prototypes tested to over 12 tonnes
- Full Factory Parts Backup
- CE Marked

A ROBUST, RELIABLE, LOW COST RAIL GRAB SMALL ENOUGH TO FIT THE TOOLBOX OF MOST RRV'S

DOCUMENTATION

Operator's Manual
Parts Manual
Maintenance Plan
LOLER Test Certificate



BENEFITS

Cam mechanism means no linkage to jam

Fully enclosed mechanism means reduced damage

High strength means the Autolok will withstand the heavy duty use associated with modern RRV's



Specifications given may be subject to change due to our policy of continuous improvement

OPTIONS AND ORDERING INFORMATION

The ARG08 Autolok Rail Grab is available in Manual and Hydraulic versions and can be specified for handling either running rail, conductor rail or grooved rail.

When ordering an Autolok for grooved rail please specify the particular rail to be lifted.

All versions have been prototype tested to 12 tonnes to ensure their safety in an arduous working environment.



Example: ARG08-01-01 manual Autolok grab for running rails.

PRODUCT ACCEPTANCE

An application has been filed with Network Rail since 2008. We await a response.

MODEL NUMBERS FOR ORDERING

When ordering an ARG08 Rail Grab please use the order code below to specify the various options.

ARG08-□□-□□

Grab Type	Code
<i>Manual Operation</i>	01
<i>Hydraulic Operation</i>	02

Rail Type	Code
<i>Running Rail</i>	01
<i>Conductor Rail</i>	02
<i>Grooved Rail</i>	03

1.5 RLB20 RAIL BEAM



The Thomson RLB20 Rail Beam is the ideal solution for lorry cranes and excavators handling short lengths of new rail or full lengths of scrap rail.

Using the same fail-safe cam mechanism as many of our other rail handling and panel beams this light, robust little beam is designed for long life with minimal maintenance.

Fitted with a hydraulic rotator, safety lift sensing valve, system pressure control valve and check valves on the grab cylinders this is a top specification product which is used on excavators, lorry loading cranes and rail mounted maintenance machines.



FEATURES

- Lightweight & Compact
- Fail-safe Cam Mechanism
- Red-flag jaw safety indicators
- High Strength
- All Steel Construction
- High Resistance to Dynamic Loads
- High Resistance to Abuse
- Proven in Use Since 2007
- 2,000 kg WLL
- 4,000 kg Proof Load
- Full Factory Parts Backup
- CE Marked

A STRONG, SAFE, RELIABLE RAIL HANDLING BEAM FOR DELIVERY AND SITE APPLICATIONS

SPECIFICATIONS

Weight (C/W rotator and head)	285 kg
WLL (Safe Working Load)	2,000 kg
Proof Load (Factory test)	4,000 kg
Mechanism	Cam Operated
Indication	'Red Flag' Indicator
O/A Height	710 mm
O/A Width	290 mm
O/A Length	1300 mm

Max. Hyd. Pressure	210 Bar
Min. Hyd. Pressure	90 Bar
Body Colour	08E51 Yellow
Moving Parts	Signal Red

DOCUMENTATION

Operator's Manual
Parts Manual
Maintenance Plan
LOLER Test Certificate
Pads No. 094/002030



BENEFITS

- Cam mechanism means no linkage to jam and fail safe operation
- Fully enclosed mechanism means reduced damage
- High strength for durability



Specifications given may be subject to change due to our policy of continuous improvement

OPTIONS AND ORDERING INFORMATION

The RLB20 Rail Beam is available with a full range of adapter heads to suit excavators and truck mounted cranes.

As standard a parachute valve is installed to prevent the inadvertent release of the load when lifting. For special applications such as scrap handling the parachute valve can be omitted from the specification.

Where the parachute valve is omitted the operator must put in place a safe system of work to cope with the increased risk of operation.



PRODUCT ACCEPTANCE

This product has full Network Rail Product Acceptance under Certificate number 05/02964

Example: RLB20-02-07 Rail Beam with parachute valve and special adapter head for handling scrap rail with a tipper lorry

MODEL NUMBERS FOR ORDERING

When ordering this product please use the ordering code below to specify the correct options

RLB20-□□-□□

Beam Type	Code
No Parachute Valve	01
With Parachute Valve	02

Adapter Type	Code
Beam with flange only	00
Fixed head for swivel hook	01
Swivel head for fixed hook	02
Rotator + 1 pin head	03
Rotator + 2 pin head	04
Archimedes / QC adapter head	05
Rotator + truck crane adapter	06
Special Adapter	07

NOTE

When ordering adapter heads we will need to know the dimensions of your host machine.

Please see Section 10 for details of the dimensions we require for each type of adapter head.

See Section 10 for adapter types and details

1.6 RT211 CUTTLEFISH RAIL TURNER



The RT211 Rail Turner from Thomson Engineering is our most versatile rail handling product.

Robustly constructed and with hydraulic protection through a twin pilot-operated check valve mounted directly on the cylinder this grab is easy and safe to use.

All joints are fitted with replaceable bushes and grease nipples for daily lubrication.

The unique feature of the RT211 is its ability to grab, manipulate and turn rails up to 200m in length. This makes it ideal for rail handling and rail recovery operations.



FEATURES

- Hydraulic Rotation
- Hydraulic Rail Jaws
- Hydraulic Jaw Tilt
- All Steel Construction
- High Resistance to Dynamic Loads
- High Resistance to Abuse
- Can work in any position
- 2,000 kg WLL
- 4,000 kg Proof Load
- Can grab rail from any angle
- Full Factory Parts Backup
- CE Marked

THE MOST VERSATILE AND USEFUL RAIL MANIPULATOR ON THE MARKET TODAY

SPECIFICATIONS

Weight approx.	650 kg
WLL (Safe Working Load)	2,000 kg
Proof Load (Factory test)	4,000 kg
Mechanism	Fully Hydraulic
Min. Grip Force	40 kN
Min. Rotation Moment	9,500 kNm
O/A Width	140 mm
O/A Length	230 mm

Max. Hyd. Pressure	210 Bar
Min. Hyd. Pressure	90 Bar
Rotator Max Hyd. press.	150 Bar
Body Colour	08E51 Yellow
Jaw and cylinder	Signal Red

DOCUMENTATION

- Operator's Manual
- Parts Manual
- Maintenance Plan
- LOLER Test Certificate
- PADS No. 094/011081

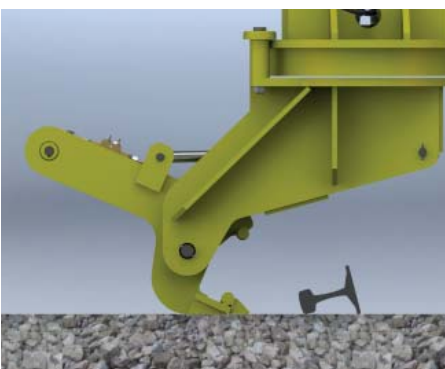

BENEFITS

- Recover rails of any length from anywhere
- Copes easily with overturned rails
- No need for manual handling or rolling of rails

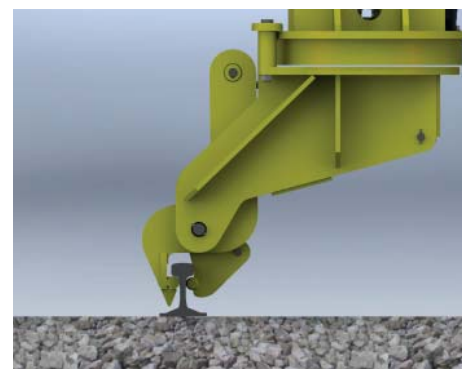

Specifications given may be subject to change due to our policy of continuous improvement

OPTIONS AND ORDERING INFORMATION

The RT211 Cuttlefish Rail Turner is available with or without pressure control valves on the grab and tip hydraulic systems.

Pressure control should be specified where the host machine system pressure exceeds 210 Bar.

When ordering we will need to know the required dimensions for the adapter head. Adapter heads are available with fixed pins for quick couplers or with removable pins for direct coupling to the excavator boom.

A transport / storage stillage is available for this product.

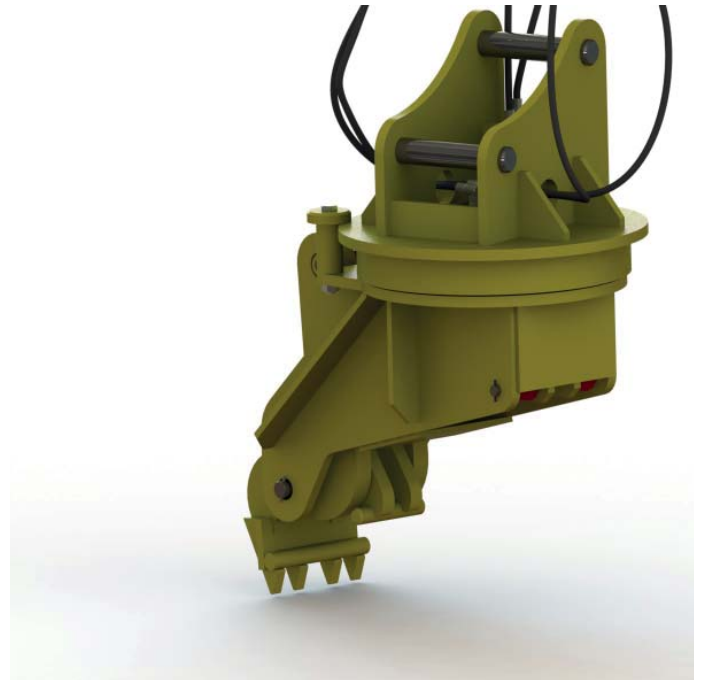

Example: RT211-01-01 Rail Turner with no pressure control valve or stillage

PRODUCT ACCEPTANCE

This product has full Network Rail Product Acceptance under Certificate number 05/05230

MODEL NUMBERS FOR ORDERING

When ordering this product please use the ordering code below to specify the correct options

RT211-□□-□□

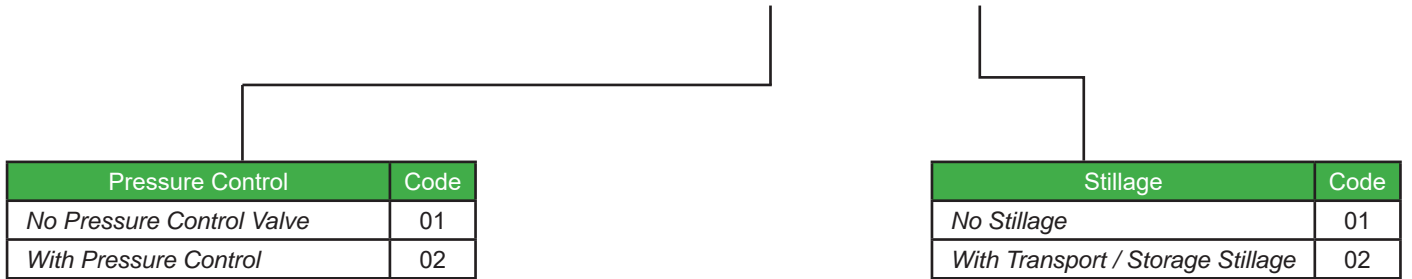

NOTE

When ordering we will need to know the dimensions of your host machine in order to manufacture the adapter head.

Please see Section 10 for details of the dimensions we require for a Type 04 head

1.7 UB02 UNIVERSAL LIFTING BEAM



The Thomson Universal Lifting Beam is the industry standard solution for tandem lift panel handling but it is also capable of use as a rail handling beam.

Each end of the beam has hydraulic rail jaws mounted in turntable mounts which allow the jaws to rotate to change from panel mode to rail handling mode.

The 10,000kg Safe Working Load means that the beams have plenty of strength for the task!

A load sensing valve prevents the jaws from opening when the beam is carrying a load.



SPECIFICATIONS

Weight (Standard)	380 kg
Weight (with rotator) typical	460 kg
WLL (Safe Working Load)	10,000 kg
Proof Load (Factory test)	20,000 kg
Mechanism	Hydraulic
Indication	Jaws visible to operator
O/A Height	Depends on config.
O/A Width	380mm
O/A Length	1820 mm

Max. Hyd. Pressure	210 Bar
Min. Hyd. Pressure	90 Bar
Body Colour	08E51 Yellow
Moving Parts	Signal Red



BENEFITS

- Multi-purpose beam
- High reliability, low maintenance
- Rotator, swivel head and low-headroom attachment head options
- Built-in pressure control to prevent overloading of hydraulic system

FEATURES

- Jaws on rotating mounts
- Load sensing safety valve
- All Steel Construction
- High Resistance to Dynamic Loads
- High Resistance to Abuse
- Proven in Use Since 2000
- 10,000 kg WLL
- 20,000 kg Proof Load
- Rotator, swivel head and low-headroom adapter head versions available
- Full Factory Parts Backup
- CE Marked

THE MOST VERSATILE AND POPULAR COMBINATION LIFTING BEAM ON THE MARKET

DOCUMENTATION

- Operator's Manual
- Parts Manual
- Maintenance Plan
- LOLER Test Certificate
- PADS No. 094/002028



Specifications given may be subject to change due to our policy of continuous improvement

OPTIONS AND ORDERING INFORMATION

The UB02 Universal Lifting Beam is available for standard and broad gauge track panels.

Broad gauge beams are compatible with all track gauges, standard gauge beams are compatible with standard and narrow gauge only.

The beam is fitted as standard with pressure control and a parachute valve to prevent inadvertent release of the load when lifted.

We strongly recommend that, when used for tandem lifting of track panels, at least one of the beams should be fitted with a swivel or fixed head for hook attachment to the host machine.

A transport / storage stillage is available for this product.

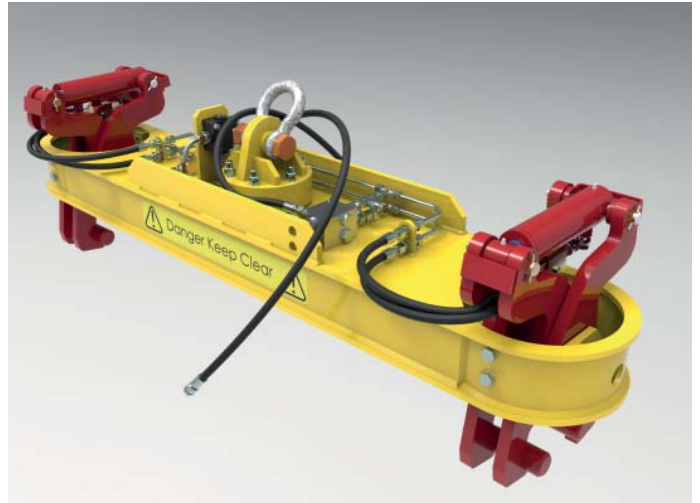

Example: UB02-01-01-01 Universal Lifting Beam, standard gauge, with fixed head for swivel hook and no stillage

PRODUCT ACCEPTANCE

This product has full Network Rail Product Acceptance under Certificate number 05/02004

MODEL NUMBERS FOR ORDERING

When ordering this product please use the ordering code below to specify the correct options

UB02-□□-□□-□□

Beam Type	Code
Standard Gauge	01
1600mm Broad Gauge	02

Stillage	Code
No Stillage	01
With Transport / Storage Stillage	02

Adapter Type	Code
Beam with flange only	00
Fixed head for swivel hook	01
Swivel head for fixed hook	02
Rotator + 1 pin head	03
Rotator + 2 pin head	04
Archimedes / QC adapter head	05
Rotator + truck crane adapter	06
Special Adapter	07

NOTE

When ordering adapter heads we will need to know the dimensions of your host machine.

Please see Section 10 for details of the dimensions we require for each type of adapter head.

See Section 10 for adapter types and details

1.8 TRLB20 TELESCOPIC RAIL LIFTING BEAM



Our TRLB20 Telescopic Rail Beam is the first choice for handling new rails up to 20m in length.

This beam is the only hydraulic rail beam certified by Network Rail for handling new rail.

A variety of versions are now available for handling running rail, conductor rail and grooved rail.

Many of these beams are in use on rail delivery lorries where their ease of integration with lorry loading cranes is much appreciated.

TRLB20 Telescopic Rail Beams are supplied with transport stands as standard equipment.

SPECIFICATIONS

Weight (Typical)	650 kg
WLL (Safe Working Load)	1,250 kg
Proof Load (Factory test)	2,500 kg
Mechanism	Cam Operated
Indication	'Red Flag' Indicator
O/A Height (spec. shown)	910 mm
O/A Width	290 mm
O/A Length	3,600 to 6,200 mm



Max. Hyd. Pressure	210 Bar
Min. Hyd. Pressure	90 Bar
Body Colour	08E51 Yellow
Moving Parts	Signal Red

FEATURES

- Lightweight & Compact
- Fail-Safe Cam Mechanism
- Running rail, conductor rail and grooved rail versions available
- Manual and hydraulic telescoping versions
- High Strength
- All Steel Construction
- High Resistance to Dynamic Loads
- High Resistance to Abuse
- Proven in Use Since 2006
- 1,250 kg WLL
- 2,500 kg Proof Load
- Automatic clamping of telescopic sections
- 'Red-Flag' jaw status indicators
- Full Factory Parts Backup
- CE Marked

DOCUMENTATION

- Operator's Manual
- Parts Manual
- Maintenance Plan
- LOLER Test Certificate
- PADS No. 094/002031



BENEFITS

- Cam mechanism means no linkage to jam
- Fully enclosed mechanism means reduced damage
- The only hydraulic beam currently accepted by Network Rail for the handling of new rail in 18m lengths



Specifications given may be subject to change due to our policy of continuous improvement

OPTIONS AND ORDERING INFORMATION

The TRLB20 Telescopic Rail Lifting Beam is available with either manual or hydraulic telescopic extension.

The manual version is automatically clamped at the set length when the grab jaws are closed, a manual valve is used to release the clamps to allow the beam to be adjusted.

The hydraulic extension version incorporates an automatic changeover system which allows the operator to level the load once the beam has been lifted.



Example: TRLB20-01-05 Telescopic Rail Lifting Beam with manual extension and Archimedes square drive adapter head.

PRODUCT ACCEPTANCE

This product has full Network Rail Product Acceptance under Certificate number 05/02965

MODEL NUMBERS FOR ORDERING

When ordering this product please use the ordering code below to specify the correct options

TRLB20-□□-□□

Beam Type	Code
<i>Manual Extension</i>	01
<i>Hydraulic Extension</i>	02

Adapter Type	Code
<i>Beam with flange only</i>	00
<i>Fixed head for swivel hook</i>	01
<i>Swivel head for fixed hook</i>	02
<i>Rotator + 1 pin head</i>	03
<i>Rotator + 2 pin head</i>	04
<i>Archimedes / QC adapter head</i>	05
<i>Rotator + truck crane adapter</i>	06
<i>Special Adapter</i>	07

NOTE

When ordering adapter heads we will need to know the dimensions of your host machine.

Please see Section 10 for details of the dimensions we require for each type of adapter head.

See Section 10 for adapter types and details

1.9 RT10 UNIVERSAL RAIL THIMBLE



The RT10 Universal Rail Thimble supports and manipulates long welded rail using four rollers running under the rail head.

This thimble's design means that it can work with any flat bottom running rail without any adjustments being required. Rail does not need to be lifted onto blocks to allow the thimble to begin work.

A key feature of the RT10 is the well guarded hydraulic cylinder which prevents damage in rough use.

Prototype units were tested to twenty tonnes during development proving the strength and durability.



FEATURES

- Strong and Robust
- Fully protected hydraulic cylinder
- Bronze bushes throughout
- All Steel Welded Construction
- High Resistance to Dynamic Loads
- High Resistance to Abuse
- Proven in Use Since 2002
- 2,000 kg WLL
- 4,000 kg Proof Load
- Prototypes tested to 20 tonnes
- Soft rollers available for coated rails.
- Full Factory Parts Backup
- CE Marked

A STRONG AND EASY TO USE THIMBLE FOR ALL FLAT BOTTOM RUNNING RAILS

SPECIFICATIONS

Weight	235 kg
WLL (Safe Working Load)	2,000 kg
Proof Load (Factory test)	4,000 kg
Mechanism	Hydraulic
O/A Height	735 mm
O/A Width	730mm
O/A Length	630 mm

Max. Hyd. Pressure	210 Bar
Min. Hyd. Pressure	90 Bar
Body Colour	08E51 Yellow
Cylinder colour	Signal Red

DOCUMENTATION

- Operator's Manual
- Parts Manual
- Maintenance Plan
- LOLER Test Certificate
- PADS No. 094/020080



BENEFITS

No adjustments necessary for different rail sections

Check valve protects against hose failure

Simple and safe to use



Specifications given may be subject to change due to our policy of continuous improvement

OPTIONS AND ORDERING INFORMATION

The RT10 Rail Thimble is designed for threading all types of running rail without adjustment.

The Thimble is available with or without a pressure control valve. Pressure control should be specified when the system pressure of the host machine exceeds 200 Bar.



Example: RT10-01-01 Thimble with no pressure control valve or stillage

PRODUCT ACCEPTANCE

This product has full Network Rail Product Acceptance under Certificate number 05/03274

MODEL NUMBERS FOR ORDERING

When ordering this product please use the ordering code below to specify the correct options

RT10-□□-□□

Thimble Type	Code
No Pressure Control Valve	01
With Pressure Control valve	02

Stillage	Code
No Stillage	01
With Transport / Storage Stillage	02

NOTE

When ordering for use outside the UK we will need to know the types of rail to be used with this product

Please contact the factory to confirm compatibility

1.12 TD15 THREADER DRAGGER



The TD15 Threader Dragger is a unique solution to the handling of long welded rails.

Combining a Rail Foot Thimble with a hydraulic Drag Clamp the TD15 can drag and thread both running rails and conductor rails without having to change attachments.

The device can also be used to 'pick and place' rails and to lift and load short rail sections.

With a rated pull capacity of 10,000kgf and a lift capacity of 2,000kg the TD15 Threader Dragger is designed and built for a long working life.

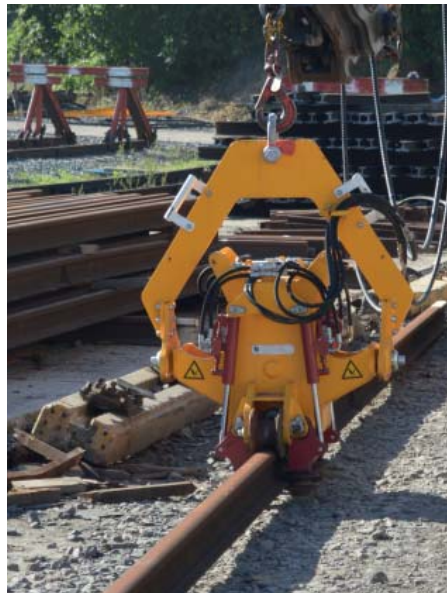

FEATURES

- 50 tonne grip force on dragger
- Hardened steel jaws
- For use with running and conductor rails
- Durable Case Hardened threading rollers
- Check valves on cylinders
- Hardened steel bushes on grab
- Instant change from dragging to threading and vice versa
- Lifting eyes to raise rail end when dragging

THE COMPLETE SOLUTION FOR THE HANDLING, REMOVAL AND INSTALLATION OF LONG WELDED RUNNING AND CONDUCTOR RAILS.

SPECIFICATIONS

Weight	710 kg
WLL (Safe Working Load)	2,000 kg
Max. Pull force	10,000 kgf
Mechanism	Fully Hydraulic
O/A Height (shipping)	910 mm
O/A Width	1125 mm
O/A Length	1320 mm

Max. Hyd. Pressure	210 Bar
Min. Hyd. Pressure	90 Bar
Body Colour	08E51 Yellow
Moving Parts	Signal Red
Handles	White

DOCUMENTATION

- Operator's Manual
- Parts Manual
- Maintenance Plan
- LOLER Test Certificate



BENEFITS

- Instant changeover between functions
- Reduced rail installation time
- Two-in-one versatility
- Long working life

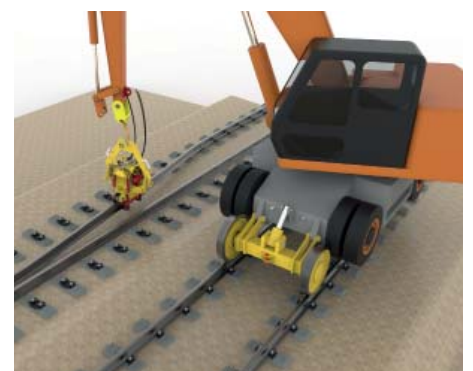

Specifications given may be subject to change due to our policy of continuous improvement

OPTIONS AND ORDERING INFORMATION

The TD15 Threader Dragger is only available in one version and suits all machines of sufficient capacity.

As standard a pressure control valve is fitted to the drag clamp system. The threader system can also be fitted with pressure control if required.

A transport / storage stillage is available for this product.



Example: TD15-01-02 Threader Dragger with standard hydraulic system and stillage

PRODUCT ACCEPTANCE

This product has full Network Rail Product Acceptance under Certificate number PA05/06670

MODEL NUMBERS FOR ORDERING

When ordering this product please use the ordering code below to specify the correct options

TD15-□□-□□

Threader Dragger Type	Code
<i>Standard Hydraulic System</i>	01
<i>Pressure Control on Threader</i>	02

Stillage	Code
<i>No Stillage</i>	01
<i>With Transport / Storage Stillage</i>	02

NOTE

When ordering for use outside the UK we will need to know the types of rail to be used with this product

Please contact the factory to confirm compatibility

1.13 RFT15 RAIL FOOT THIMBLE



A truly universal rail thimble for threading all types of flat bottom rail including both running rail and conductor rail sections.

The hydraulic cylinders allow the Rail Foot Thimble to grip the base of the rail section securely and to guide it accurately into place.

A special mechanism automatically withdraws the rollers a precise amount as the rail is lifted to ensure smooth running.



FEATURES

- Strong and Robust
- Fully protected hydraulic cylinders
- Greased bushes throughout
- All steel construction
- High resistance to dynamic loads
- Universal application
- Case hardened rollers and shafts
- 2,000 kg WLL
- Prototypes tested to 12,000kg
- Full Factory Parts Backup
- CE Marked

A UNIQUE DESIGN OF THIMBLE FOR ALL FLAT BOTTOM RUNNING AND CONDUCTOR RAILS.

SPECIFICATIONS

Weight	250 kg
WLL (Safe Working Load)	2,000 kg
Proof Load (Factory test)	4,000 kg
Mechanism	Fully Hydraulic
O/A Height (typical)	580mm
O/A Width	480mm
O/A Length	550 mm

Max. Hyd. Pressure	210 Bar
Min. Hyd. Pressure	90 Bar
Body Colour	08E51 Yellow
Moving Parts	Signal Red
Handles	White

DOCUMENTATION

- Operator's Manual
- Parts Manual
- Maintenance Plan
- LOLER Test Certificate
- PADS No.094/013617



BENEFITS

- No adjustment necessary for different rail sections
- Check valve protects against hose failure
- Works with all flat bottom rails
- Replaceable rollers and shafts



Specifications given may be subject to change due to our policy of continuous improvement

OPTIONS AND ORDERING INFORMATION

The RFT15 Rail Foot Thimble is usually supplied for direct connection to a pressure controlled circuit on the host machine.

If required, however, a pressure reducing valve can be fitted to the Rail Foot Thimble to prevent over-pressurising of the hydraulic system.

This can be specified as type RFT15-02.

A transport / storage stillage can also be specified if required.



Example: RFT15-02-01 Rail Foot Thimble with pressure control valve - no stillage

PRODUCT ACCEPTANCE

This product has full Network Rail Product Acceptance under Certificate number 05/05727

MODEL NUMBERS FOR ORDERING

When ordering a RFT15 Rail Foot Thimble please use the order code below to specify the correct options

RFT15-□□-□□

Hydraulic System	Code
No Pressure Control	01
Pressure Reducing Valve	02

Stillage	Code
Thimble only - no stillage	01
With Transport / storage stillage	02

NOTE

When ordering for use outside the UK we will need to know the types of rail to be used with this product

Please contact the factory to confirm compatibility

1.16 MRH14 MULTI-RAIL HANDLER



The Thomson Multi Rail Handler is designed for the lifting of packs of rails in bulk deliveries.

The twin hitch points - each fitted with a safety bow shackle - allow the device to handle part loads.

Manual (illustrated), pneumatic and hydraulic versions are available.

Multi Rail Handlers can be made to suit any rail section including conductor and grooved rails.

Multi Rail Handlers can also be supplied in any configuration from 1 to 10 rails and units can be strung together on spreader beams for larger loads.



FEATURES

- Manual or Hydraulic Actuation
- Twin hitch points for odd and even numbers of rails
- Heavy duty construction
- Pneumatic, Hydraulic and Manual options
- Gate latch security for handle
- All joints fitted with grease nipples.
- Full Factory Parts Backup
- CE Marked

A LOW-COST GRAB BUILT FOR HEAVY DUTY USE, SIMPLE SERVICING AND RELIABLE OPERATION.

SPECIFICATIONS(TYPICAL)

Weight	115 kg
WLL (Safe Working Load)	6,000 kg
Proof Load (Factory test)	10,000 kg
Mechanism	Hyd. / Pneu. / Manual
O/A Height (typical)	495mm
O/A Width	290mm
O/A Length	890mm

Max. Hyd. Pressure	190 Bar
Min. Hyd. Pressure	90 Bar
Body Colour	08E51 Yellow
Moving Parts	Signal Red
Operating Handle	White

DOCUMENTATION

Operator's Manual
Parts Manual
Maintenance Plan
LOLER Test Certificate



BENEFITS

- Handle up to 8 rails per lifter
- Rapid loading and unloading of rails
- All versions can be used with spreader beams for handling long rail lengths



Specifications given may be subject to change due to our policy of continuous improvement

OPTIONS AND ORDERING INFORMATION

The MRH14 Multi Rail Handler can be specified for handling 1 to 8 rails per lift.

The standard model is operated by a manual handle but hydraulic and pneumatic versions are also available.

Spreader beams can also be used to link two or more units side-by-side for special applications: please contact the factory for special installations.

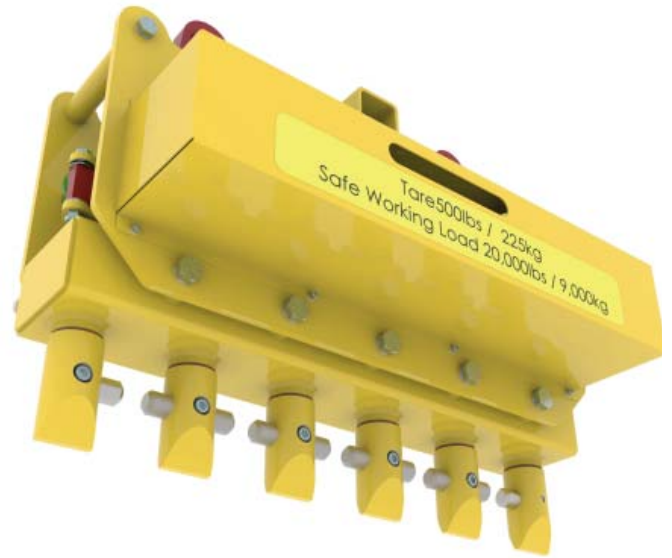

Example: MRH14-02-05 Multi Rail Lifter with pneumatic operation for lifting 5 rails

PRODUCT ACCEPTANCE

This product is intended for use in rail handling yards, dockyards, etc.
No application has been made for Network Rail Product Acceptance

MODEL NUMBERS FOR ORDERING

When ordering Multi Rail Handlers please use the order code below to specify the required options.

MRH14-□□-□□

Operation	Code
Manual Lever	01
Pneumatic	02
Hydraulic	03

Number of Rails	Code
1 rail	01
2 rails	02
3 rails	03
4 rails	04
5 rails	05
6 rails	06
7 rails	07
8 rails	08

NOTE

When ordering we will need to know the rail type to be handled

1.18 RHB16 RAIL HANDLING BEAM

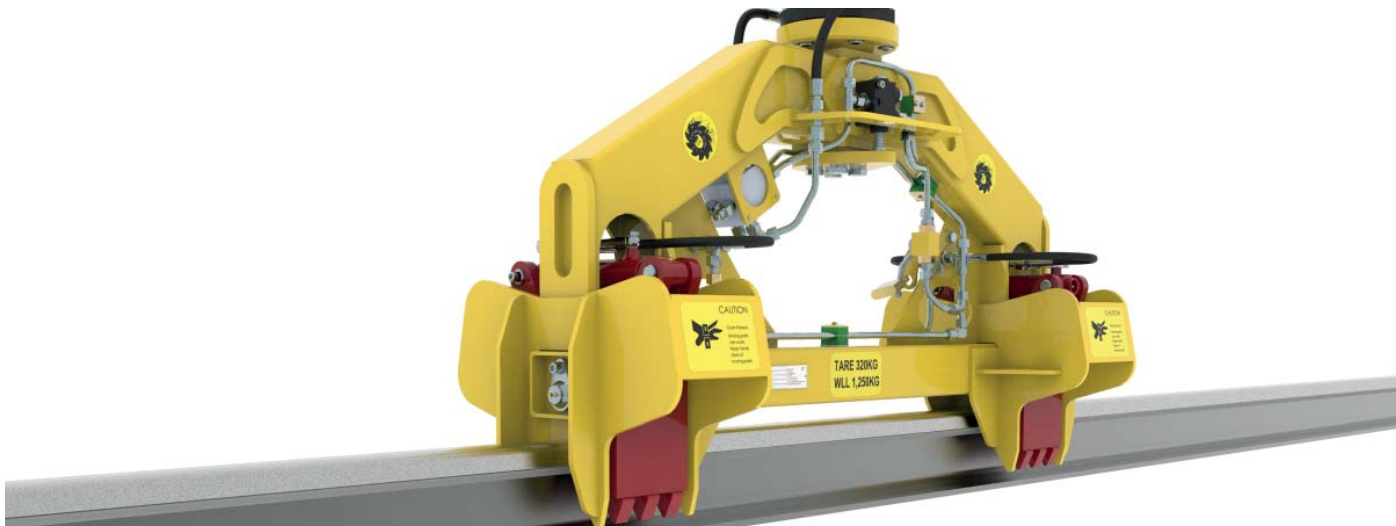

Designed for use with excavators and lorry mounted cranes the RHB16 Rail Handling Beam is specifically intended for use in rail delivery operations.

The unique design of the jaws allows rails to be stacked foot-to-foot to maximise load capacity on trucks and rail wagons.

A parachute valve prevents inadvertent dropping of the load but this can be overridden if used to load scrap rail into bins.

The heavy duty construction includes a six-tonne capacity rotator and an all-steel heavy section frame.

Check valves on the cylinders protect against leakage and burst hoses.



SPECIFICATIONS(TYPICAL)

Weight	325 kg
WLL (Safe Working Load)	1,250 kg
Proof Load (Factory test)	2,500 kg
Rotator rating (where fitted)	6,000 kg
Mechanism	Hydraulic
O/A Height (typical)	1,430mm
O/A Width	500mm
O/A Length	1,275mm

Max. Hyd. Pressure (grab)	290 Bar
Min. Hyd. Pressure (grab)	90 Bar
Max. Hyd. Pressure (rotate)	160 Bar

Body Colour	08E51 Yellow
Hydraulic Cylinder	Signal Red
Jaws	Signal Red



BENEFITS

- Pack rails tightly on trucks and wagons
- One man operation
- Use with either truck mounted crane or excavator



FEATURES

- Full Hydraulic Actuation
- Unique Jaw Design
- Parachute Valve
- Heavy duty construction
- Stack Rails Foot-to-Foot
- All joints fitted with grease nipples.
- Full Factory Parts Backup
- CE Marked

A HEAVY DUTY GRAB DESIGNED SPECIFICALLY FOR RAIL DELIVERY OPERATIONS.

DOCUMENTATION

- Operator's Manual
- Parts Manual
- Maintenance Plan
- LOLER Test Certificate



OPTIONS AND ORDERING INFORMATION

The RHB16 Rail Handling Beam is available in two versions: with or without the parachute safety valve.

The basic beam has a 6 bolt standard rotator flange mounting but can be factory-supplied with a wide variety of adapter head options including hydraulic rotators (see Section 10 for full details).

This beam can also be fitted with an adapter head for our quick change truck crane adapter system.

Standard colours are as shown but alternative paint schemes are available - please contact the sales team for details.



Example: RHB16-02-06-01 beam with parachute valve, rotator and truck crane adapter head, no stillage

PRODUCT ACCEPTANCE

This product is primarily specified for road haulage of rail sections and for loading and unloading rails in handling yards

As such no application has yet been made for Product Acceptance however Thomson Engineering will be pleased to make an application if required

MODEL NUMBERS FOR ORDERING

When ordering a RHB16 Rail Handling Beam please use the order code below to specify the correct options.

RHB16-□□-□□-□□

Beam Type	Code
No Parachute Valve	01
With Parachute Valve	02

Stillage	Code
No stillage	01
With Transport / Storage Stillage	02

Adapter Type	Code
Beam with flange only	00
Fixed head for swivel hook	01
Swivel head for fixed hook	02
Rotator + 1 pin head	03
Rotator + 2 pin head	04
Archimedes / QC adapter head	05
Rotator + truck crane adapter	06
Special Adapter	07

NOTE

When ordering adapter heads we will need to know the dimensions of your host machine.

Please see Section 10 for details of the dimensions we require for each type of adapter head.

See Section 10 for adapter types and details

Section 2: Sleeper Handling

2.1 CSH09 SLEEPER HANDLER



The CSH09 Sleeper Handler is primarily designed as an attachment for lorry self-loading cranes.

The device is adjustable to cope with a wide range of sleeper widths, depths and lengths. Wear pads are fitted to reduce damage from exposed reinforcing rods common to continental sleepers.

Adjustment is simple and damage to the sleepers is prevented by the fitment of rubber protectors to the contact areas.

The device may be supplied fitted with a hydraulic rotator or a simple swivel hook attachment point.



FEATURES

- Strong and Reliable
- Check valves on hydraulic cylinders
- Heavy Duty slide ways
- All Steel Welded Construction
- High Resistance to Dynamic Loads
- High Resistance to Abuse
- Proven in Use Since 2009
- 2,000 kg WLL
- 4,000 kg Proof Load
- Full Factory Parts Backup
- CE Marked

A VERSATILE SLEEPER LOADING GRAB FOR ROAD HAULAGE APPLICATIONS

SPECIFICATIONS

Weight (4 sleeper model)	525 kg
WLL (Safe Working Load)	2,000 kg
Proof Load (Factory test)	4,000 kg
Mechanism	Hydraulic
O/A Height	960 mm
O/A Width	1515mm
O/A Length (min)	2040 mm

Max. Hyd. Pressure (grab)	290 Bar
Min. Hyd. Pressure (grab)	90 Bar
Max. Hyd. Pressure (rotate)	160 Bar

Body Colour	08E51 Yellow
Cylinders	Signal Red
Handles	White

DOCUMENTATION

Operator's Manual
Parts Manual
Maintenance Plan
LOLER Test Certificate

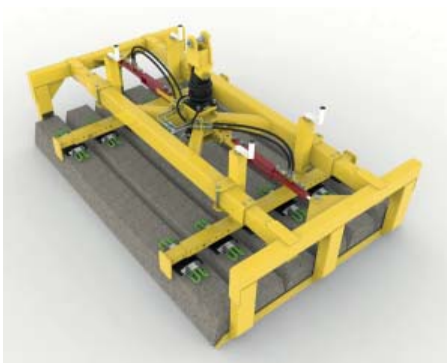

BENEFITS

- Check valves on cylinders protect against hose failure
- All known wear points fitted with replaceable wear parts
- Designed for long life and hard work

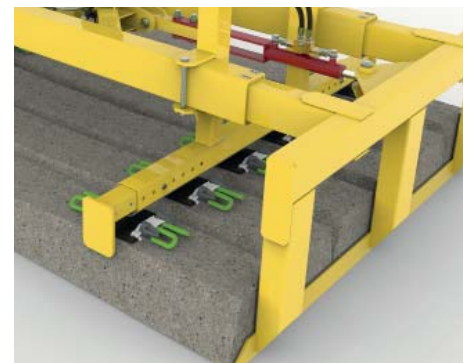

Specifications given may be subject to change due to our policy of continuous improvement

OPTIONS AND ORDERING INFORMATION

The CSH09 Sleeper Handler is available in four and six-sleeper models.

The device may be specified with our full range of adapter heads for excavator or truck crane mounting.

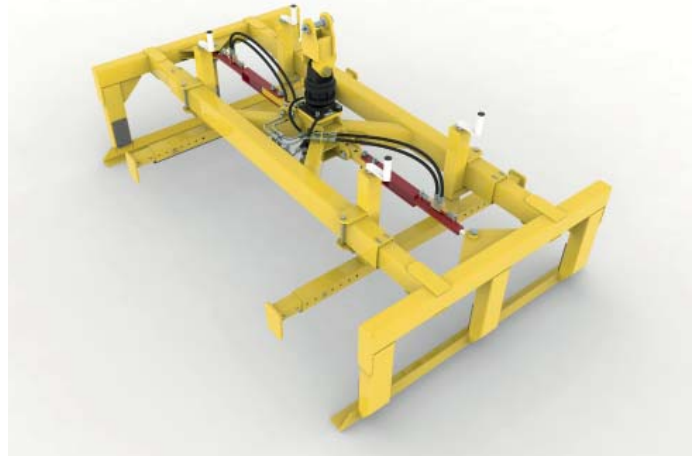

Example: CSH09-06-06 Six-Sleeper Handler with rotator and truck mounted crane adapter.

PRODUCT ACCEPTANCE

This product is primarily specified for use with lorry mounted cranes in the road haulage of sleepers

As such no application has been made for Product Acceptance however Thomson Engineering will be pleased to make an application if required

MODEL NUMBERS FOR ORDERING

When ordering this product please use the ordering code below to specify the correct options

CSH09-□□-□□

Handler Capacity	Code
<i>Four Sleepers</i>	04
<i>Six Sleepers</i>	06

Adapter Type	Code
<i>Grab with flange only</i>	00
<i>Fixed head for swivel hook</i>	01
<i>Swivel head for fixed hook</i>	02
<i>Rotator + 1 pin head</i>	03
<i>Rotator + 2 pin head</i>	04
<i>Archimedes / QC adapter head</i>	05
<i>Rotator + truck crane adapter</i>	06
<i>Special Adapter</i>	07

NOTE

When ordering adapter heads we will need to know the dimensions of your host machine.

Please see Section 10 for details of the dimensions we require for each type of adapter head.

See Section 10 for adapter types and details

2.2 SM12 SLEEPER MANIPULATOR



The Thomson Sleeper Manipulator is designed for the precision handling and placement of steel, concrete and timber sleepers.

Interchangeable jaw pads are supplied: urethane lined for concrete, patterned for timber and with base bar for steel sleepers.

Jaws open to 400mm and close to 200mm to accommodate all sleeper types and the 500 kg Safe Working Load allows this grab to handle even the longest bearers.

Pressure control, fitted as standard, prevents overloading of the grab mechanism.

SPECIFICATIONS

Weight	635 kg
WLL (Safe Working Load)	500 kg
Proof Load (Factory test)	1,000 kg
Mechanism	Hydraulic
Jaw Range	200 - 400mm
O/A Height	1075 mm
O/A Width	700 mm
O/A Length	825 mm



Max. Hyd. Pressure	210 Bar
Min. Hyd. Pressure	90 Bar
Grip Force (@200 Bar)	74,600 N
Body Colour	08E51 Yellow
Cylinder Colour	Red

FEATURES

- Rotating or interchangeable jaws for steel, concrete and timber sleepers
- Urethane pads for concrete sleepers eliminate damage
- Hydraulic rotator
- Two pin mounting to host machine
- Heavy duty construction
- Twin jaw cylinders with check valves
- 500 kg WLL
- 1,000 kg Proof Load
- Full Factory Parts Backup
- CE Marked

AN IDEAL SOLUTION FOR PRECISION SLEEPER HANDLING AND FOR SLEEPER CHANGING.

DOCUMENTATION

Operator's Manual
Parts Manual
Maintenance Plan
LOLER Test Certificate



BENEFITS

Narrow profile for ease of access to clips / chairs

Fully enclosed mechanism means reduced damage

Hydraulic rotation and 2 pin mounting mean precise sleeper positioning and manipulation



Specifications given may be subject to change due to our policy of continuous improvement

OPTIONS AND ORDERING INFORMATION

The SM12 Sleeper Manipulator is supplied with a two pin head for fitting to an excavator.

When ordering please specify the adapter head dimensions to suit your host machine.

A transport / storage stillage is available for this product.

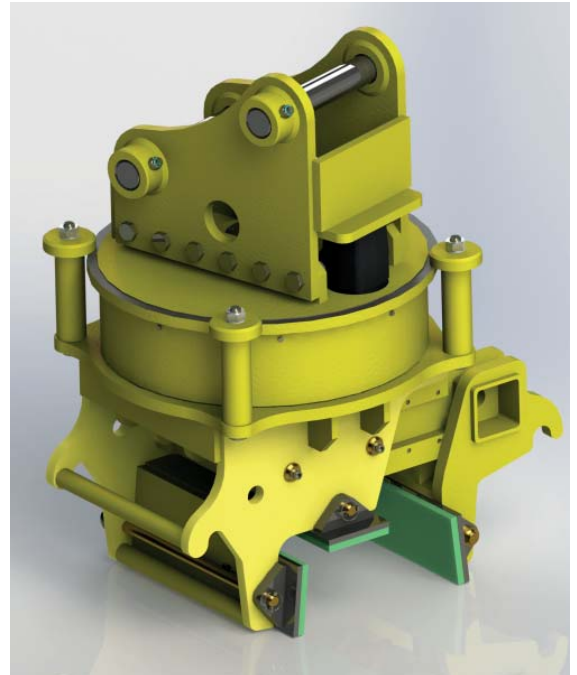

Example: SM12-01 Sleeper Manipulator without stillage.

PRODUCT ACCEPTANCE

This product has been developed primarily for overseas markets and has not to date been presented for Network Rail Product Approval

MODEL NUMBERS FOR ORDERING

When ordering this product please use the ordering code below to specify the correct options

SM12-□□

Stillage	Code
No Stillage	01
With Transport / Storage Stillage	02

NOTE

When ordering we will need to know the dimensions of your host machine in order for us to provide the correct adapter head

Please see Section 10 for details of the dimensions we require for Type 04 adapter head.

2.4 SSB16 SLEEPER SPREADER BEAMS



Thomson Engineering manufacture a wide range of sleeper spreader beams.

Designs are available for handling 4, 7, 8, 14 or 28 sleepers according to application; either self powered and radio controlled or linked to the crane's hydraulic system.

All our models feature light, rigid fabricated subframes, strong lifting legs and soft contact pads to eliminate damage to the sleepers.

All are designed to gather sleepers together prior to lifting for the most accurate results.

Our Super-Light 7-Sleeper model weighs just 950kg.

SPECIFICATIONS

Application	Concrete Sleepers
Capacity	4,7,8,14 or 28 sleepers
Power source	Crane or power pack
Control	Crane Auxiliary Pendant Radio Remote
WLL (Safe Working Load)	350 kg/leg
Proof Load (Factory Test)	700 kg/leg



Max. Hyd. Pressure	210 Bar
Min. Hyd. Pressure	90 Bar
Body Colour	08E51 Yellow
Moving Parts	Signal Red

FEATURES

- Strong and Robust
- Check valves on grip cylinders
- Precision Spacing
- Variety of models including Super Light
- All Steel Welded Construction
- High Resistance to Dynamic Loads
- Handles sleepers up to 350 kg
- Twin jib crane model available
- Optional sleeper gathering feature
- Full Factory Parts Backup
- CE Marked

A WIDE VARIETY OF OPTIONS AND EXCELLENT LOAD TO WEIGHT RATIO.

DOCUMENTATION

Operator's Manual
Parts Manual
Maintenance Plan
LOLER Test Certificate



BENEFITS

- Rapid and safe sleeper laying
- Reduces or eliminates working at height
- Accurate sleeper spacing



Specifications given may be subject to change due to our policy of continuous improvement

OPTIONS AND ORDERING INFORMATION

The SSB16 Sleeper Spreader Beam is a unique modular design which can be made to carry from 4 to 28 sleepers.

Smaller models (4 and 7 sleeper) are also available with an all aluminium alloy chassis making them the lightest in their class.

Special types include models with built in power packs and radio control for use with gantry cranes.



Example: SSB16-03-04 Seven Sleeper Spreader Beam with alloy chassis, rotator and two-pin adapter head

PRODUCT ACCEPTANCE

This product has full Network Rail Product Acceptance under Certificate number PA05/06744

MODEL NUMBERS FOR ORDERING

When ordering this product please use the ordering code below to specify the correct options

SSB16-□□-□□

Type	Code
Four Sleepers Alloy Chassis	01
Four Sleepers Steel Chassis	02
Seven Sleepers Alloy Chassis	03
Seven Sleepers Steel Chassis	04
Eight Sleepers Steel Chassis	05
Special Type (please specify)	06

Adapter Type	Code
Beam with flange only	00
Fixed head for swivel hook	01
Swivel head for fixed hook	02
Rotator + 1 pin head	03
Rotator + 2 pin head	04
Archimedes / QC adapter head	05
Rotator + truck crane adapter	06
Special Adapter	07

NOTE

When ordering adapter heads we will need to know the dimensions of your host machine.

Please see Section 10 for details of the dimensions we require for each type of adapter head.

See Section 10 for adapter types and details

2.10 CSG14 CONCRETE SLEEPER PACK GRAB



Thompson Concrete Sleeper Pack Grabs have a unique design which allows them to be quickly and easily adjusted to handle 1, 2, 3, 4 or 5 layers of sleepers.

The unique, hydraulically-adjusted top plate allows the grab to be set for the required number of layers in a matter of moments.

With a 10,000kg Safe Working Load this is an extremely heavy duty unit which can be fitted with standard or heavy duty rotators and adapter heads to suit excavators up to 50 tonnes.

The standard model handles up to 25 sleepers in 5 layers.



FEATURES

- Handles up to 5 layers
- Rubber buffers protect sleepers
- All Steel Welded Construction
- Long design life
- Hydraulic adjustment
- 10,000kg WLL
- Other sizes available
- Single and multiple layers
- Full Factory Parts Backup
- CE Marked

A PURPOSE DESIGNED CONCRETE SLEEPER PACK GRAB FOR USE WITH HEAVY EXCAVATORS

SPECIFICATIONS

Typical unit for 25 sleepers:

Tare Weight	3,600 kg
WLL (Safe Working Load)	10,000 kg
Proof Load (Factory Test)	20,000 kg
Mechanism	Fully hydraulic
Sleeper Length	2,500 mm
Pack width	1,500 mm

Max. Hydraulic Pressure	210 Bar
Min. Hydraulic Pressure	100 Bar

Frame Colour	08E51 Yellow
Moving Parts	Signal Red

DOCUMENTATION

Operator's Manual
Parts Manual
Maintenance Plan
LOLER Test Certificate



BENEFITS

- Rapid loading of trains and trucks
- Purpose designed for heavy duty use
- Available for 1 to 5 layers of sleepers



Specifications given may be subject to change due to our policy of continuous improvement

OPTIONS AND ORDERING INFORMATION

The CSG14 Concrete Sleeper Pack Grab is available with our full range of adapter heads.

The device may be specified for one to five layers of sleepers to suit different host machine capacities.



Example: CSG14-05-04 Concrete Sleeper Pack Grab for 25 sleepers with rotator and two-pin adapter head

PRODUCT ACCEPTANCE

This product is primarily specified for use in handling yards and not therefore on Network Rail infrastructure

As such, no Product Acceptance is required for this grab

MODEL NUMBERS FOR ORDERING

When ordering this product please use the ordering code below to specify the correct options

CSG14-□□-□□

Grab Capacity	Code
5 Sleepers	01
10 Sleepers	02
15 Sleepers	03
20 Sleepers	04
25 Sleepers	05

Adapter Type	Code
Beam with flange only	00
Fixed head for swivel hook	01
Swivel head for fixed hook	02
Rotator + 1 pin head	03
Rotator + 2 pin head	04
Archimedes / QC adapter head	05
Rotator + truck crane adapter	06
Special Adapter	07

NOTE

When ordering adapter heads we will need to know the dimensions of your host machine.

Please see Section 10 for details of the dimensions we require for each type of adapter head.

See Section 10 for adapter types and details

2.11 PG14 PLATE GRAB

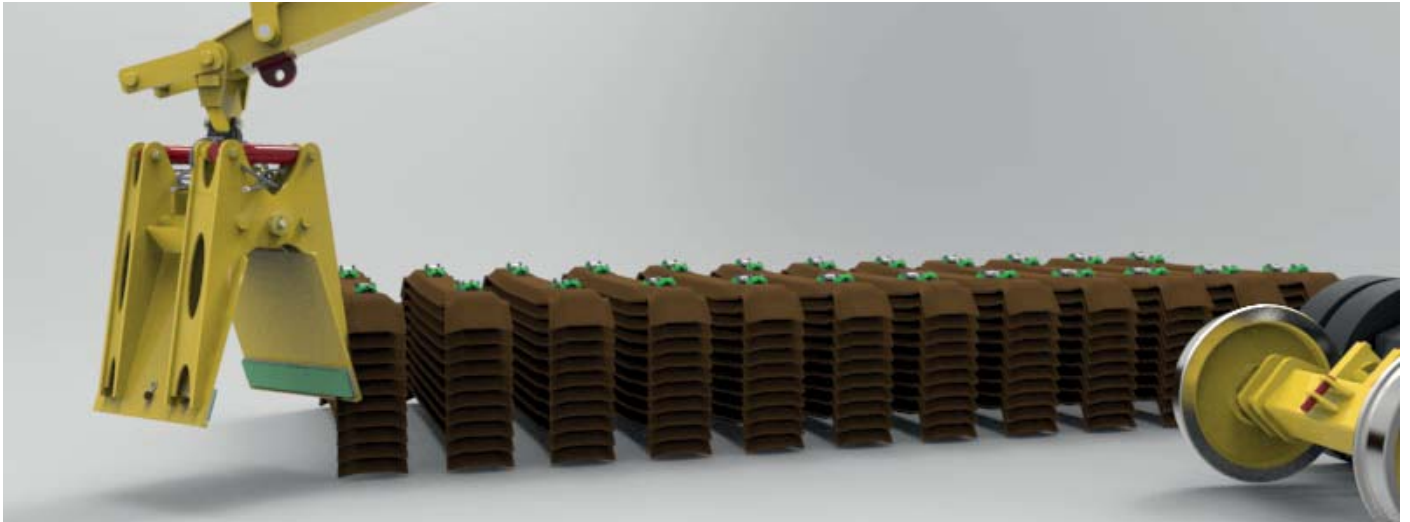

The Thomson Plate Grab is designed for handling short lengths of rail, packs of steel sleepers and single concrete sleepers.

The only plate grab to come with easily removable soft gripper pads which prevent damage to concrete sleepers.

Jaws open wide for stability in transport yet close to touch for gripping small items.

Available with jaw depths of 400mm, 600mm or 800mm and a variety of rotators and adapters to suit all machines and cranes.



FEATURES

- Steel jaw lip
- Urethane pads for concrete
- Hydraulic Rotator
- Two pin or one pin adapter heads
- Heavy Duty Welded Construction
- Check valves on cylinders
- 1,250 kg WLL
- Three jaw heights available
- Full Factory Parts Backup
- CE Marked

A HEAVY DUTY PLATE GRAB FOR SLEEPER AND GENERAL PURPOSE HANDLING

SPECIFICATIONS

Typical unit for 25 sleepers:

Tare Weight (typical)	850 kg
WLL (Safe Working Load)	1,250 kg
Proof Load (Factory Test)	2,500 kg
Mechanism	Fully hydraulic
O/A Width	800 mm
Jaw Max Opening	950 mm
Adapter Mount	Std 6 bolt flange

Max. Hydraulic Pressure	210 Bar
Min. Hydraulic Pressure	90 Bar
Body Colour	08E51 Yellow
Hyd. Cylinders	Signal Red
Soft Pad	800mm x 140mm

DOCUMENTATION

Operator's Manual
Parts Manual
Maintenance Plan
LOLER Certificate



BENEFITS

- Range of sizes available
- High Grip Force
- Quick fit pads for concrete sleepers
- General purpose heavy duty handler



Specifications given may be subject to change due to our policy of continuous improvement

OPTIONS AND ORDERING INFORMATION

The PG14 Plate Grab is available with three different jaw depths to suit different applications.

The device may be specified with our full range of adapter heads for excavator or truck crane mounting.



Example: PG14-03-05 Plate Grab with 800mm deep jaws and Archimedes square drive adapter head

PRODUCT ACCEPTANCE

This product is primarily specified for use in handling yards

As such no application has been made for Product Acceptance however Thomson Engineering will be pleased to make an application if required

MODEL NUMBERS FOR ORDERING

When ordering this product please use the ordering code below to specify the correct options

PG14-□□-□□

Grab Depth	Code
400mm	01
600mm	02
800mm	03

Adapter Type	Code
Beam with flange only	00
Fixed head for swivel hook	01
Swivel head for fixed hook	02
Rotator + 1 pin head	03
Rotator + 2 pin head	04
Archimedes / QC adapter head	05
Rotator + truck crane adapter	06
Special Adapter	07

NOTE

When ordering adapter heads we will need to know the dimensions of your host machine.

Please see Section 10 for details of the dimensions we require for each type of adapter head.

See Section 10 for adapter types and details

2.12 TCSG16 SLEEPER GRAB

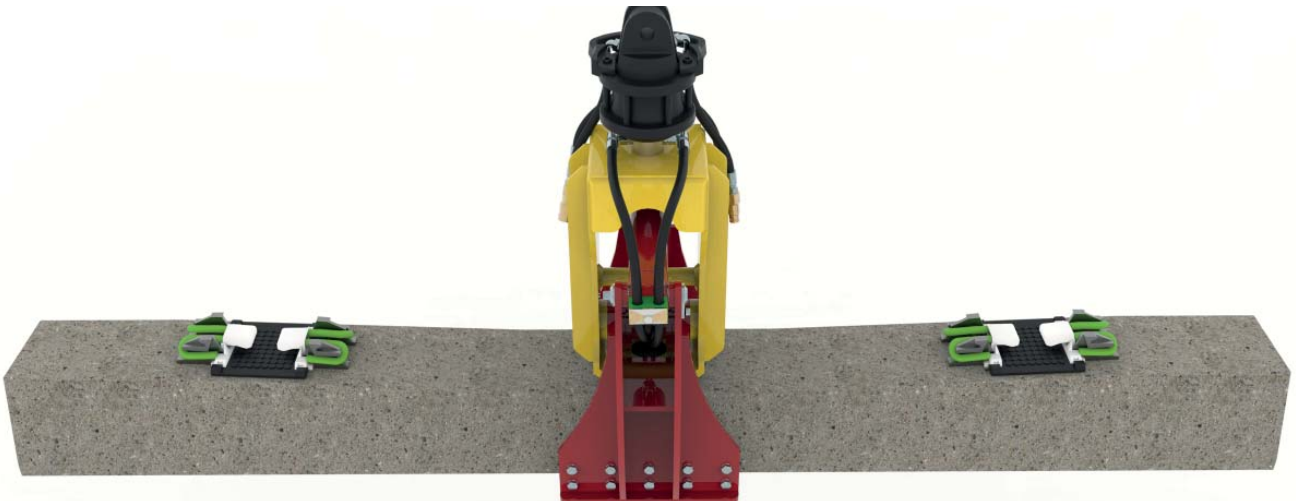

The Thomson TCSG16 Sleeper Grab is designed for use in the haulage and delivery of concrete, steel and timber sleepers.

Specifically designed for use with truck cranes.

The delicate surfaces of concrete sleepers are protected by the soft grip pads.

A pilot operated check valve secures the cylinder against hose failure for extra safety.

Computer Aided Engineering has been used extensively to minimise the weight of this product without compromising strength or performance.

SPECIFICATIONS

Grab with rotator but no adapter head:

Tare Weight	130 kg
WLL (Safe Working Load)	1,250 kg
Proof Load (Factory Test)	2,500 kg
Mechanism	Fully hydraulic
O/A Width	590 mm
Jaw Length	350 mm
Jaw Max Opening	345 mm



Max. Hydraulic Pressure	210 Bar
Min. Hydraulic Pressure	90 Bar
Body Colour	08E51 Yellow
Moving Parts	Signal Red
Soft Pad	350mm x 80mm

FEATURES

- Steel jaw lip
- Urethane pads to protect sleepers
- Hydraulic Rotator
- Full range of adapter heads
- Heavy Duty Welded Construction
- Check valve on cylinder
- 1,250 kg WLL
- Specifically designed for truck cranes
- Lift concrete, timber or steel sleepers
- Full Factory Parts Backup
- CE Marked

A LIGHT BUT HEAVY DUTY GRAB FOR SLEEPER PURPOSE HANDLING

DOCUMENTATION

Operator's & Maintenance Manual
LOLER Certificate



BENEFITS

- Light weight
- Versatile
- High Grip Force
- Soft Grip pads for concrete sleepers
- Heavy duty design



Specifications given may be subject to change due to our policy of continuous improvement

OPTIONS AND ORDERING INFORMATION

The TCSG16 Sleeper Grab is available as a grab only, as a grab with rotator or as grab, rotator and adapter head.

The device may be specified with our full range of adapter heads for excavator or truck crane mounting.

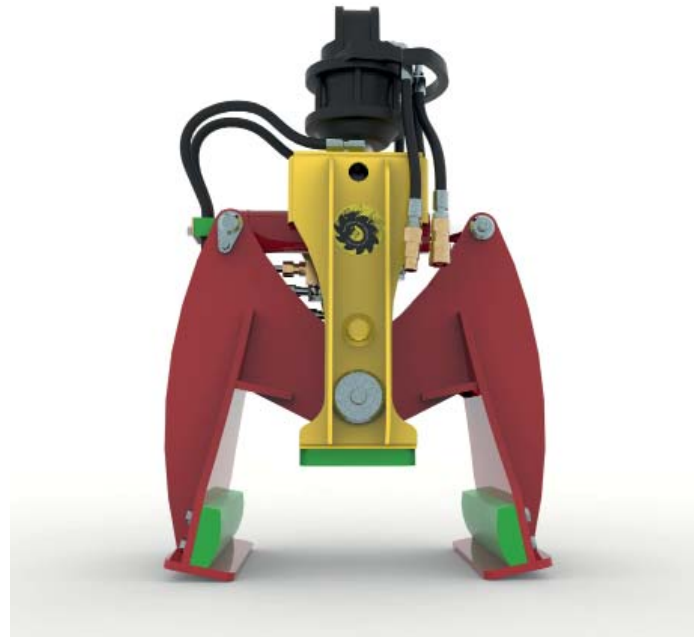

Example: TCSG16-02-00 Sleeper Grab with rotator but no adapter head

PRODUCT ACCEPTANCE

This product is primarily specified for use in road haulage

As such no application has been made for Product Acceptance however Thomson Engineering will be pleased to make an application if required

MODEL NUMBERS FOR ORDERING

When ordering this product please use the ordering code below to specify the correct options

TCSG16-□□-□□

Grab Configuration	Code
<i>Grab only</i>	01
<i>Grab with Rotator only</i>	02
<i>Grab with rotator & adapter</i>	03

Adapter Type	Code
<i>No Adapter head</i>	00
<i>Fixed head for swivel hook*</i>	01
<i>Swivel head for fixed hook*</i>	02
<i>1 pin rotator head</i>	03
<i>2 pin rotator head</i>	04
<i>Archimedes / QC adapter head*</i>	05
<i>Rotator + truck crane adapter</i>	06
<i>Special Adapter</i>	07

NOTE

When ordering adapter heads we will need to know the dimensions of your host machine.

Please see Section 10 for details of the dimensions we require for each type of adapter head.

** TCSG16-01 only
See Section 10 for adapter types and details*

Section 3: Panel Handling

3.1 UNIVERSAL LIFTING BEAM



The Thomson Universal Lifting Beam is the industry standard device for tandem lifting of track panels.

Rated to 10,000kg Safe Working Load each beam is factory tested to 20,000kg and designed to withstand even higher dynamic loads.

Built-in pressure control and automatic locking of the jaws whilst lifting ensures that this beam is extremely safe in use.

The jaws themselves can be rotated to convert this beam into a rail beam.

Hydraulic rotator version available.



FEATURES

- Strong and Robust
- Fully protected hydraulic cylinders
- Bronze bushes in jaws
- Rotating Jaw Assemblies
- All Steel Welded Construction
- High Resistance to Dynamic Loads
- High Resistance to Abuse
- Proven in Use Since 2000
- 10,000 kg WLL
- 20,000 kg Proof Load
- Full Factory Parts Backup
- CE Marked

THE INDUSTRY STANDARD PANEL LIFTING BEAM FOR TANDEM LIFT OPERATIONS

SPECIFICATIONS

Weight (spec. shown)	380 kg
WLL (Safe Working Load)	10,000 kg
Proof Load (Factory test)	20,000 kg
Mechanism	Fully Hydraulic
Indication	Jaws Visible to Operator
O/A Height (spec. shown)	575 mm
O/A Width	350mm
O/A Length	1820 mm

Max. Hyd. Pressure	210 Bar
Min. Hyd. Pressure	90 Bar
Body Colour	08E51 Yellow
Moving Parts	Signal Red

DOCUMENTATION

- Operator's Manual
- Parts Manual
- Maintenance Plan
- LOLER Test Certificate
- PADS No. 094/002028

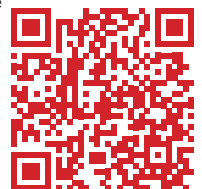

BENEFITS

- Proven strength, reliability and durability
- Variety of configurations available
- Can be used as a rail beam



Specifications given may be subject to change due to our policy of continuous improvement

OPTIONS AND ORDERING INFORMATION

The UB02 Universal Lifting Beam is available for standard and broad gauge track panels.

Note that the rotating jaws allow a broad gauge beam to be used for handling standard and narrow gauge panels. Similarly a standard gauge unit can also handle narrow gauge panels but will not work with broad gauge track.

The beam is fitted as standard with pressure control and a parachute valve to prevent inadvertent release of the load when lifted.

We strongly recommend that, when used for tandem lifting of track panels, at least one of the beams should be fitted with a swivel or fixed head for hook attachment to the host machine.

A transport / storage stillage is available for this product.

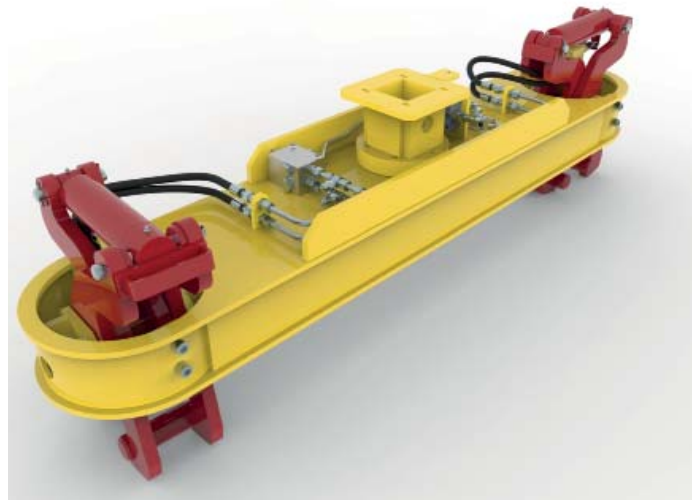

Example: UB02-01-05-01 Universal Lifting Beam, standard gauge, with Archimedes square drive head and no stillage

PRODUCT ACCEPTANCE

This product has full Network Rail Product Acceptance under Certificate number 05/02004

MODEL NUMBERS FOR ORDERING

When ordering this product please use the ordering code below to specify the correct options

UB02-□□-□□-□□

Beam Type	Code
Standard Gauge	01
1600mm Broad Gauge	02

Stillage	Code
No Stillage	01
With Transport / Storage Stillage	02

Adapter Type	Code
Beam with flange only	00
Fixed head for swivel hook	01
Swivel head for fixed hook	02
Rotator + 1 pin head	03
Rotator + 2 pin head	04
Archimedes / QC adapter head	05
Rotator + truck crane adapter	06
Special Adapter	07

NOTE

When ordering adapter heads we will need to know the dimensions of your host machine.

Please see Section 10 for details of the dimensions we require for each type of adapter head.

See Section 10 for adapter types and details

3.2 LH11 LOW HEADROOM PANEL BEAMS

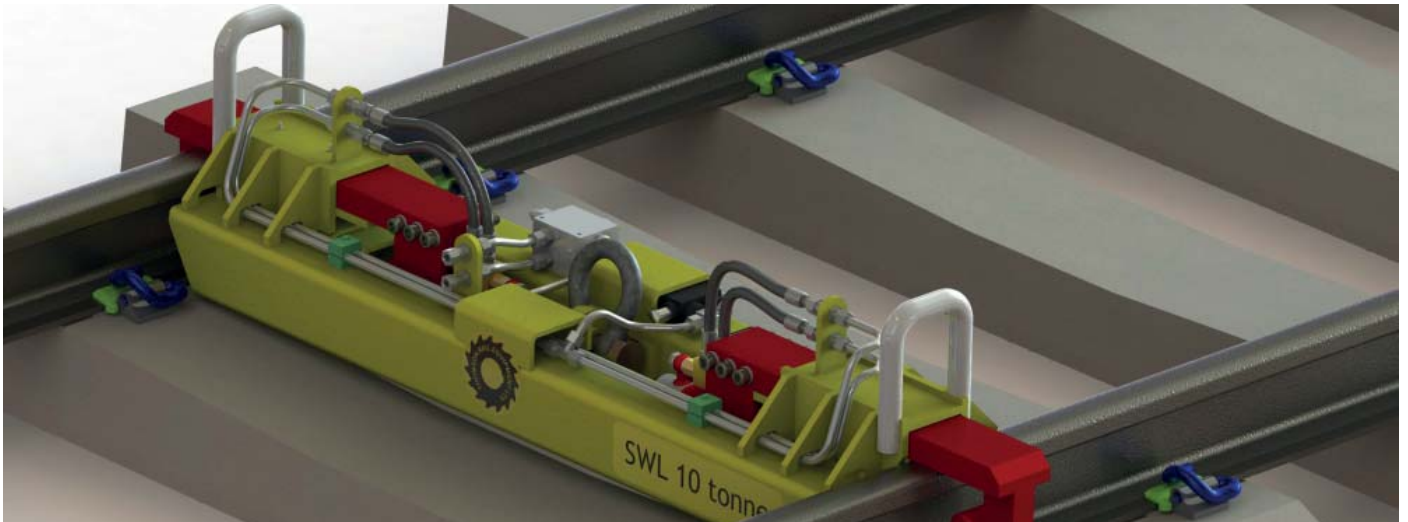

Where track panels have to be recovered and stacked under live overhead equipment, every inch of headroom is vital.

The Thomson Low Headroom Panel Beams have a hitch point just a few millimeters above the level of the rail head, maximising headroom to maximise the number of panels which can be stacked on a wagon in tunnels and under overhead wires.

With a Safe Working Load of 10 tonnes, load sensing safety valves and check valves on both cylinders these beams are the safe answer to panel handling in low-headroom situations.



FEATURES

- Strong and Robust
- Fully protected hydraulic cylinders
- Shielded pipework to prevent damage
- All Steel Welded Construction
- High Resistance to Dynamic Loads
- High Resistance to Abuse
- 10,000 kg WLL
- 20,000 kg Proof Load
- Full Factory Parts Backup
- CE Marked

A LOW HEADROOM DESIGN TO GIVE EXTRA CAPACITY UNDER OLE.

SPECIFICATIONS

Weight	400 kg
WLL (Safe Working Load)	10,000 kg
Proof Load (Factory test)	20,000 kg
Mechanism	Sliding Jaw
O/A Height	400 mm
O/A Width	360mm
O/A Length	1630 mm

Max. Hyd. Pressure	210 Bar
Min. Hyd. Pressure	90 Bar
Body Colour	08E51 Yellow
Moving Parts	Signal Red
Handles	White

DOCUMENTATION

Operator's Manual
Parts Manual
Maintenance Plan
LOLER Test Certificate

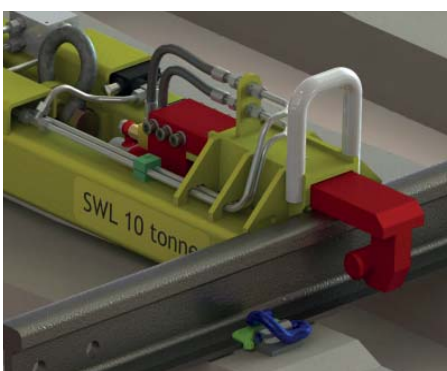

BENEFITS

- Easier working under OLE
- Fail-safe operation
- High strength to withstand the heavy duty use associated with modern RRV's

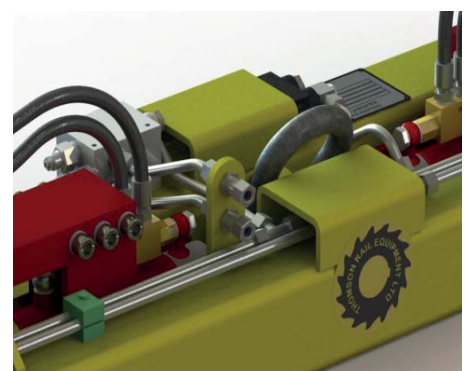

Specifications given may be subject to change due to our policy of continuous improvement

OPTIONS AND ORDERING INFORMATION

The LH11 Low Headroom Panel Beam is available in two models: for standard gauge and broad gauge track.

This beam is only available with a type 01 adapter (fixed head for swivel hook) which is fitted as standard.

A transport / storage stillage is available for this product.



PRODUCT ACCEPTANCE

This product has been designed for underground applications

No application has been made for Network Rail Product Acceptance

Example: LH11-01-01 Panel Beam for standard gauge track with no stillage

MODEL NUMBERS FOR ORDERING

When ordering this product please use the ordering code below to specify the correct options

LH11-□□-□□

Beam Type	Code
Standard Gauge	01
1600mm Broad Gauge	02

Stillage	Code
No Stillage	01
With Transport / Storage Stillage	02

3.5 SPH12 SMALL PANEL HANDLER

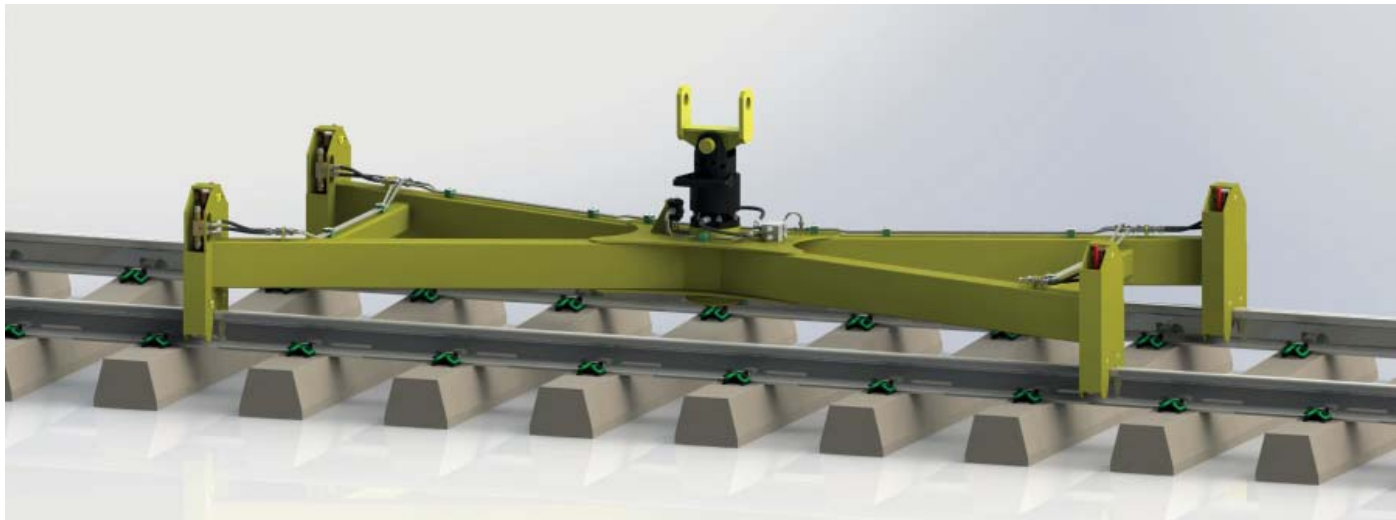

Handling track panels up to 10m long and 6,000kg in weight is easily and quickly done using the Thomson Small Panel Handler.

At 4.5m long this beam minimises deflection of the panel.

Its heavy duty 10,000 kg capacity hydraulic rotator gives the operator precision control of the beam and load.

Each jaw unit incorporates a 'Red-Flag' indicator to alert the operator to the status of the jaws.

Like all Thomson products this beam is designed for long-term heavy-duty operation.



FEATURES

- Strong and Robust
- Fully protected hydraulic cylinder
- Fail-Safe Cam Mechanism
- Bronze bushes in jaws
- All Steel Welded Construction
- High Resistance to Dynamic Loads
- High Resistance to Abuse
- Built-in Pressure Control
- 6,000 kg WLL
- 10,000 kg Proof Load
- Minimises Panel Deflection
- Red-Flag indicators
- Full Factory Parts Backup
- CE Marked

A HEAVY DUTY PANEL BEAM FOR PLAIN LINE PANELS UP TO 10m LONG

SPECIFICATIONS

Weight (typical)	590 kg
Rotator WLL	10,000 kg
WLL (Safe Working Load)	6,000 kg
Proof Load (Factory test)	10,000 kg
Mechanism	Cam Operated
Indication	'Red Flag' Indicator
O/A Height	650 mm
O/A Width	1,900mm
O/A Length	4,600 mm

Max. Hyd. Pressure	210 Bar
Min. Hyd. Pressure	90 Bar
Body Colour	08E51 Yellow
Moving Parts	Signal Red

DOCUMENTATION

Operator's Manual
Parts Manual
Maintenance Plan
LOLER Test Certificate

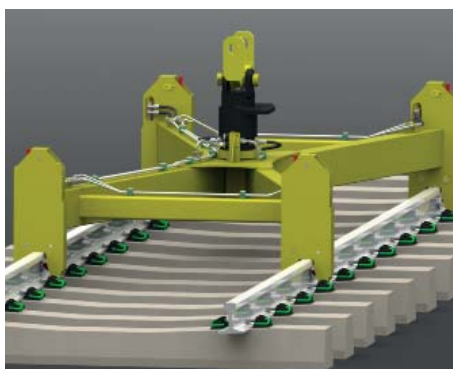
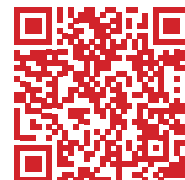

BENEFITS

- Cam mechanism means no linkage to jam.
- Fully enclosed mechanism means reduced damage
- High strength means the device will withstand the heavy duty use associated with modern RRV's



Specifications given may be subject to change due to our policy of continuous improvement

OPTIONS AND ORDERING INFORMATION

The SPH12 Small Panel Handler is available for standard and narrow gauge track panels.

The device is available with our full range of adapter head systems to suit any host machine.



Example: SPH12-01-03 Small Panel Handler for standard gauge track with hydraulic rotator and one-pin adapter head

LONDON UNDERGROUND APPROVAL

This product has been approved for use on London Underground work sites

MODEL NUMBERS FOR ORDERING

When ordering this product please use the ordering code below to specify the correct options

SPH12-□□-□□

Handler Type	Code
Standard Gauge	01
1000mm Narrow Gauge	02

Adapter Type	Code
Beam with flange only	00
Fixed head for swivel hook	01
Swivel head for fixed hook	02
Rotator + 1 pin head	03
Rotator + 2 pin head	04
Archimedes / QC adapter head	05
Rotator + truck crane adapter	06
Special Adapter	07

NOTE

When ordering adapter heads we will need to know the dimensions of your host machine.

Please see Section 10 for details of the dimensions we require for each type of adapter head.

See Section 10 for adapter types and details

3.6 PH16 HEAVY PANEL HANDLER



For plain line panels up to 20m long, weighing up to 12,000 kg the Thomson Heavy Panel Handler is the solution to single lift handling.

The Heavy Panel Handler has all the safety features of our lifting beams: load sensing safety valve, pressure control, check valves on all cylinders and a significant design safety factor.

This all adds up to a powerful and reliable tool built for long service.

This beam can be ordered with straight or arched centre section, a variety of lengths and gauges.



FEATURES

- Strong and Robust
- Fully protected hydraulic cylinder
- All Steel Welded Construction
- High Resistance to Dynamic Loads
- High Resistance to Abuse
- Proven in Use Since 2008
- 12,000 kg WLL
- 24,000 kg Proof Load
- Pressure Control Valve
- Full Factory Parts Backup
- CE Marked

A WELL PROVEN HEAVY-DUTY PANEL LIFTING SOLUTION

SPECIFICATIONS

Weight (typical)	2000 kg
Rotator Capacity (options)	16,000 kg
WLL (Std. Gauge)	12,000 kg
Proof Load (Factory test)	24,000 kg
Mechanism	Hydraulic jaws
Construction	3 Section
Length (typical)	6m

Max. Hyd. Pressure	210 Bar
Min. Hyd. Pressure	90 Bar
Body Colour	08E51 Yellow
Moving Parts	Signal Red

DOCUMENTATION

Operator's Manual
Parts Manual
Maintenance Plan
LOLER Test Certificate



BENEFITS

- Powerful, precise operation
- Fully enclosed mechanism means reduced damage
- Designed for use with heavy lifting machines



Specifications given may be subject to change due to our policy of continuous improvement

OPTIONS AND ORDERING INFORMATION

The PH16 Heavy Panel Handler is available to suit either standard gauge or broad gauge track panels.

Standard gauge models have a Working Load Limit (SWL) of 12,000kg, broad gauge models are rated to 14,000kg.

Each model is available with either a straight or an arched centre beam.



Example: PH16-01-04 Heavy Panel Handler for standard gauge track with straight centre beam, rotator and two-pin adapter head

PRODUCT ACCEPTANCE

This product is primarily specified for use in handling yards and not therefore on Network Rail infrastructure

As such, no Product Acceptance is required for this grab

MODEL NUMBERS FOR ORDERING

When ordering this product please use the ordering code below to specify the correct options

PH16-□□-□□

Beam Type	Code
Standard Gauge Straight Beam	01
Standard Gauge Arched Beam	02
1600mm Gauge Straight Beam	03
1600mm Gauge Arched Beam	04

Adapter Type	Code
Beam with flange only	00
Fixed head for swivel hook	01
Swivel head for fixed hook	02
Rotator + 1 pin head	03
Rotator + 2 pin head	04
Archimedes / QC adapter head	05
Rotator + truck crane adapter	06
Special Adapter	07

See Section 10 for adapter types and details

NOTE

When ordering adapter heads we will need to know the dimensions of your host machine.

Please see Section 10 for details of the dimensions we require for each type of adapter head.

3.8 HLB13 PANEL LIFTING HOOK BEAM



For tandem lifting of track panels with cranes which do not have a hydraulic service available the hook beam is the solution.

Each beam has a safe working load of 10 tonnes and is fitted with a swivel head and shackle for attaching to the crane hook.

The narrow hooks can be made to penetrate the ballast by using the handle to 'saw' the beam.

When used to load track panels onto a train or lorry they can eliminate the need for a man to climb onto the load to disconnect chains.



FEATURES

- Strong and Robust
- All Steel Welded Construction
- High Resistance to Dynamic Loads
- High Resistance to Abuse
- Proven in Use Since 2008
- 10,000 kg WLL
- 20,000 kg Proof Load
- Full Factory Parts Backup
- CE Marked

A LOW COST, HEAVY-DUTY PANEL LIFTING SOLUTION

SPECIFICATIONS

Weight (typical)	235 kg
WLL (Safe Working Load)	10,000 kg
Proof Load (Factory test)	20,000 kg

Body Colour 08E51 Yellow

DOCUMENTATION

Operator's Manual
Parts Manual
Maintenance Plan
LOLER Test Certificate
PADS No. 094/013701



BENEFITS

- Low cost solution to panel handling
- Eliminates working at height
- No hydraulic supply required



OPTIONS AND ORDERING INFORMATION

The HLB13 Panel Lifting Hook Beam is available for standard, broad and narrow gauge track panels.

A transport / storage stillage is available for this product.



Example: HLB13-01 Hook Lifting Beam for standard gauge track panels

PRODUCT ACCEPTANCE

This product has full Network Rail Product Acceptance under Certificate number 05/06016

MODEL NUMBERS FOR ORDERING

When ordering this product please use the ordering code below to specify the correct options

HLB13-□□

Beam Type	Code
Standard Gauge	01
1000mm Narrow Gauge	02
1600mm Broad Gauge	03

3.9 GB16 GANTRY CRANE PANEL BEAM



For plain line panels up to 20m long, weighing up to 14,000kg this beam has been specifically designed for use with gantry and portable cranes.

Different models are available to suit twin hook and single hook cranes.

The hook design simply slides on and off the panel.

Beams are custom made to order to suit the dimensions and capacity of your crane.



FEATURES

- Strong and Robust
- Single point or two point lifting
- All Steel Welded Construction
- High Resistance to Dynamic Loads
- High Resistance to Abuse
- 14,000 kg WLL
- 20,000 kg Proof Load
- Full Factory Parts Backup
- CE Marked

A SIMPLE, HEAVY-DUTY PANEL LIFTING SOLUTION

SPECIFICATIONS

Weight (GB16-02-60)	925 kg
WLL (Safe Working Load)	14,000 kg
Proof Load (Factory test)	20,000 kg
Length (typical)	6m

Body Colour 08E51 Yellow

DOCUMENTATION

Operator's Manual
Parts Manual
Maintenance Plan
LOLER Test Certificate



BENEFITS

- Low cost solution to panel handling
- Variety of designs available
- Eliminates working at height



Specifications given may be subject to change due to our policy of continuous improvement

OPTIONS AND ORDERING INFORMATION

The GB16 Gantry Crane Panel Beam is available with a single lifting point or twin lifting points and in any length from 3m to 8m.

It may be specified for standard gauge, broad gauge or 1m narrow gauge track panels

When specifying the length of the panel take care to consider the range of sleeper spacings on the panels to be lifted. The hooks must fit between the sleepers to engage with the rails correctly.

Please contact the factory for advice on the best options.



Example: GB16-02-60 Gantry Crane Beam for standard gauge track panels, dual lift, 6m in length

PRODUCT ACCEPTANCE

This product is primarily specified for use in handling yards and not therefore on Network Rail infrastructure

As such, no Product Acceptance is required for this beam

MODEL NUMBERS FOR ORDERING

When ordering this product please use the ordering code below to specify the correct options

GB16-□□-□□

Gauge	Code
Standard Gauge Centre Lift	01
Standard Gauge Dual Lift	02
1000mm Gauge Centre Lift	03
1000mm Gauge Dual Lift	04
1600mm Gauge Centre Lift	05
1600mm Gauge Dual Lift	06

Beam Length	Code
3m	30
3.5m	35
4m	40
4.5m	45
5m	50
5.5m	55
6m	60
6.5m	65
7m	70
7.5m	75
8m	80

Section 4: Ballast and Trackbed

4.2 TH09 GEOTEXTILE HANDLER



Laying geotextiles becomes easier and quicker using Thomson Geotextile Handlers.

Originally developed for use with Geosand textile which is too heavy for manual laying the concept has now been extended and the latest model will handle all geotextile rolls up to 6m wide.

The roll of fabric is supported on steel spindles which run in tapered roller bearings. These are inserted into the ends of the roll using hydraulic cylinders.

The whole operation is practically effortless for the ground staff leading to reduced fatigue and risk.



FEATURES

- Strong and Robust
- Fully protected hydraulic cylinders
- Check valves on cylinders
- High Resistance to Dynamic Loads
- High Resistance to Abuse
- Proven in Use Since 2008
- 1,250 kg WLL
- Easy and quick to use
- Handles all geotextiles up to 6m wide
- Full Factory Parts Backup
- CE Marked

REDUCES MANPOWER REQUIREMENT,
REDUCES FATIGUE AND INCREASES
SAFETY

SPECIFICATIONS

Weight (typical) 375 kg
WLL (Safe Working Load) 1,250 kg
Proof Load (Factory test) 2,500 kg
Mechanism Hydraulically Operated

Max. Hyd. Pressure 210 Bar
Min. Hyd. Pressure 90 Bar
Body Colour 08E51 Yellow

O/A Height 735 mm
O/A Width 250mm
O/A Length 1250 - 6250 mm

DOCUMENTATION

Operator's Manual
Parts Manual
Maintenance Plan
LOLER Test Certificate



BENEFITS

- One device for all roll types and sizes
- Reduced manpower requirement
- Reduced fatigue - increased safety



OPTIONS AND ORDERING INFORMATION

The TH09 Geotextile Handler is available in one version for handling all types of geotextiles.

As standard the device is fitted with pressure control to prevent overloading of the hydraulic system.

A transport / storage stillage is available for this product.



Example: TH09-01 Geotextile handler without stillage

PRODUCT ACCEPTANCE

No application has been made for Product Acceptance at the time of publication

Thomson Engineering Design will be pleased to make an application if required

MODEL NUMBERS FOR ORDERING

When ordering this product please use the ordering code below to specify the correct options.

TH09-□□

Stillage	Code
No Stillage	01
With Transport / Storage Stillage	02

4.4 BH09 BAG HOLDER

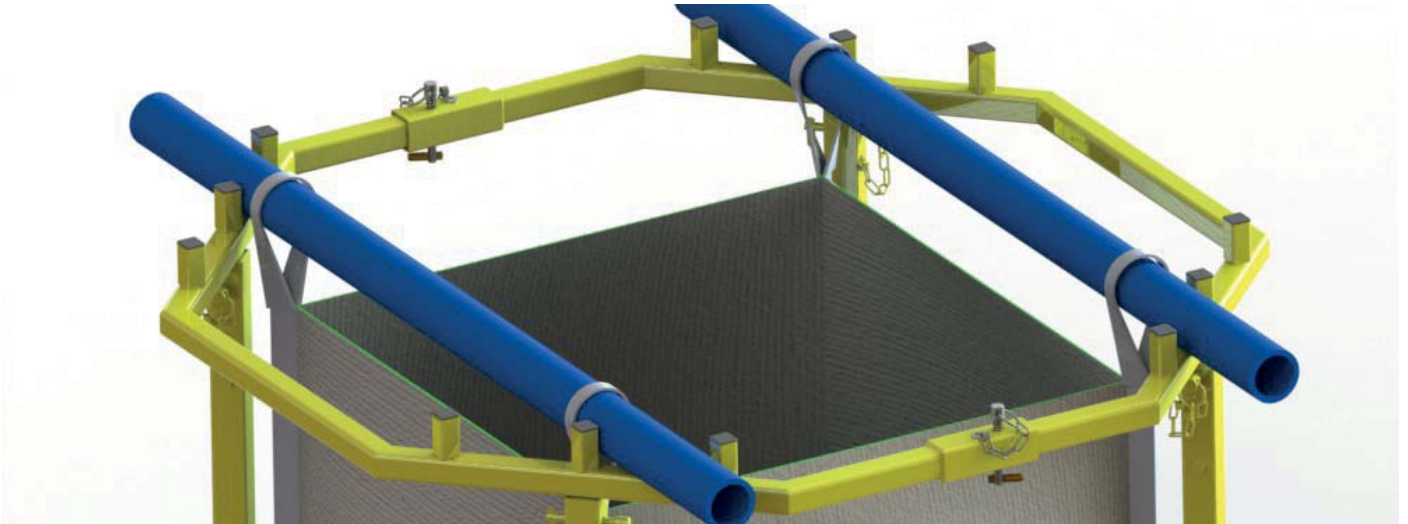

The Thomson Bag Holder is a purpose designed frame for holding open 1 tonne bulk bags for loading.

Whilst loading the bag it is securely held in the frame while the spring-loaded legs allow the bag to take up any shape without overloading any of the lifting straps.

Once loaded the bag can be lifted out through the top of the frame either using chains, a bag lifter or the purpose designed Bag Handling Forks (see page 62).

The bag support frame quickly breaks down into small sections for easy transport in a works van.



FEATURES

- Uses standard bulk bags
- Spring loaded legs on bag holder frame prevent overloading of bag loops.
- Full Factory Parts Backup
- CE Marked

A SAFE WAY OF LOADING AND HANDLING BULK BAGS

SPECIFICATIONS

Weight	45 kg	Body Colour	08E51 Yellow
		Support tubes	Blue

DOCUMENTATION

User's Instructions
Parts Manual
Maintenance Plan
LOLER Test Certificate
PADS No's. 094/001304 to 001307



BENEFITS

A safe way of supporting a standard bulk bag whilst loading

Used on its own or as part of an integrated system for loading and lifting

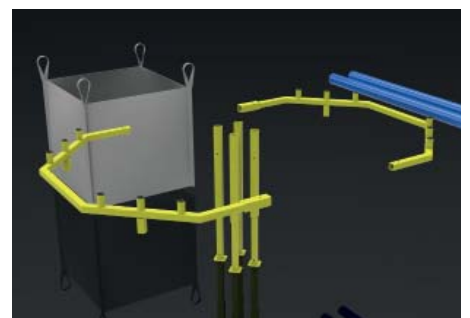

Specifications given may be subject to change due to our policy of continuous improvement

OPTIONS AND ORDERING INFORMATION

The BH09 Bag Holder is supplied as standard with one pair of bag support tubes to hold the bag handles.

If used in conjunction with the Bag Handling Forks more tubes may be required.



PRODUCT ACCEPTANCE

This product has full Network Rail Product Acceptance under Certificate number 05/04988

Example: BH09-01 Bag Holder with one pair of support tubes

MODEL NUMBERS FOR ORDERING

When ordering this product please use the ordering code below to specify the correct options

BH09-□□

No of Tube Pairs	Code
<i>1 Pair</i>	01
<i>2 Pairs</i>	02
<i>3 Pairs</i>	03

Etc.

4.4A BHF09 BAG HANDLING FORKS

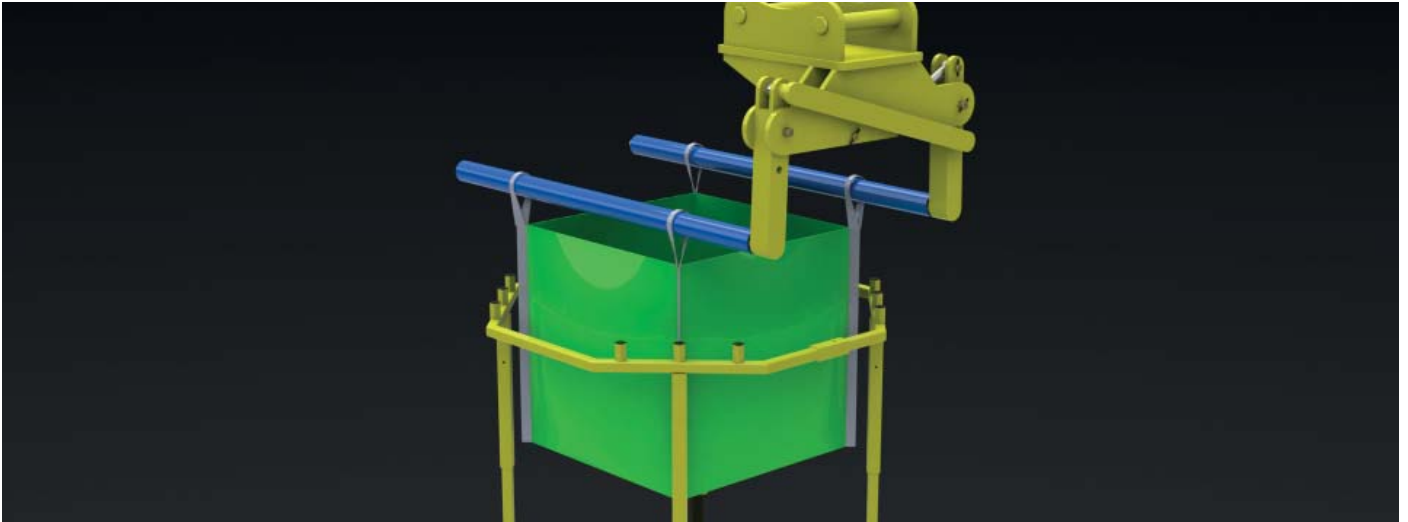

The Thomson Bag Handling Forks is a fork lifting attachment designed specifically for use with the Bag Holder.

Once loaded the fork attachment, fitted to an excavator, is used to lift and transport the bag.

The distance between the forks can be hydraulically adjusted from the cab of the machine to help align the forks with the bag support tubes.



FEATURES

- Hydraulically adjustable fork spacing
- Tapered forks for easy insertion into bag support tubes
- Full Factory Parts Backup
- CE Marked

A SAFE WAY OF LOADING AND HANDLING BULK BAGS

SPECIFICATIONS

Weight (typical)	350 kg
WLL (Safe Working Load)	1,000 kg
Proof Load (Factory test)	2,000 kg

Max. Hyd. Pressure	210 Bar
Min. Hyd. Pressure	90 Bar

Body Colour	08E51 Yellow
Cylinder	Signal Red

DOCUMENTATION

Operator's Manual
 Parts Manual
 Maintenance Plan
 LOLER Test Certificate
 PADS No's. 094/001303
 Inc. bag holder094/001302



BENEFITS

- A safe way of supporting a standard bulk bag whilst loading
- An integrated system for loading and lifting



OPTIONS AND ORDERING INFORMATION

The BHF09 Bag Handling Forks are available with either a 2-pin free-swivelling adapter head, a 2-pin free-swivelling head with hydraulic brake or with a hydraulic rotator and two-pin adapter head.

When ordering we will need to know the dimensions of the required adapter head.



Example: BHF09-02 Bag Handling Forks with free-swivel head with hydraulic brake

PRODUCT ACCEPTANCE

This product has full Network Rail Product Acceptance under Certificate number 05/04988

MODEL NUMBERS FOR ORDERING

When ordering this product please use the ordering code below to specify the correct options

BHF09-□□

Forks Type	Code
<i>2-Pin Swivel Head</i>	01
<i>2-Pin Swivel Head with Brake</i>	02
<i>Rotator & 2-Pin Head (Type 04)</i>	03

NOTE

When ordering this device we will need to know the dimensions of your host machine.

Please see Section 10 for details of the dimensions we require Type 04 heads

4.5 BC07 BAG CARRIER



The Thomson Bag Carrier is available in two sizes, both with a Safe Working Load of 2,000kg.

A strong, simple, light weight design the Bag Carrier is built for long term use and is fully CE marked and LOLER certified so it meets all the legal requirements.

Please see page 66 for details of our Multi-Bag Carrier.



FEATURES

- Strong and Light
- Two sizes available
- Proven in Use Since 2007
- 2,000 kg WLL
- 4,000 kg Proof Load
- CE Marked

A QUICK, SIMPLE SOLUTION TO THE HANDLING OF BULK BAGS UP TO 2,000KG.

SPECIFICATIONS

Weight (Large)	50 kg
Weight (Small)	37 kg
WLL (Safe Working Load)	2,000 kg
Proof Load (Factory test)	4,000 kg
Latches	Spring Operated

Body Colour 08E51 Yellow

DOCUMENTATION

Operator's / Maintenance Manual
LOLER Test Certificate

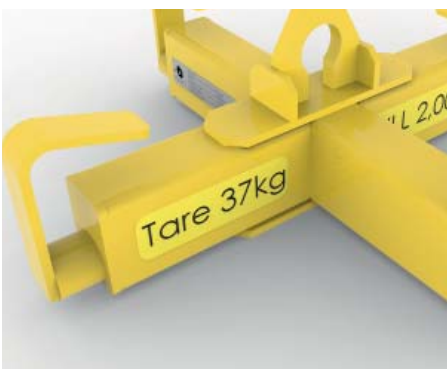

BENEFITS

- Fully certificated and tested
- Simple operation
- Light weight

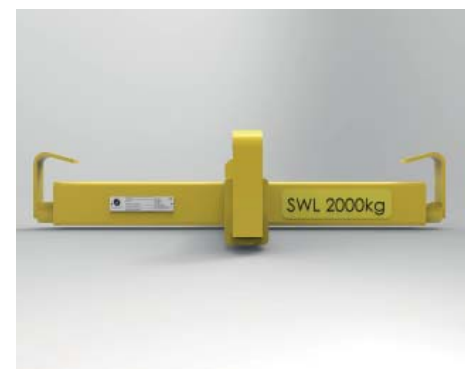

Specifications given may be subject to change due to our policy of continuous improvement

OPTIONS AND ORDERING INFORMATION

The BC07 Bag Carrier is available in two sizes:
600mm and 1000mm.

Either model can be used for handling bulk bags up to 2000kg.
The larger model is also used to hold bags open for loading.



Example: BC07-02 1000mm Bag Carrier

PRODUCT ACCEPTANCE

This product is 'loose lifting tackle' and does not require
Network Rail Product Acceptance

MODEL NUMBERS FOR ORDERING

When ordering this product please use the ordering
code below to specify the correct options

BC07-□□

Carrier Size	Code
600mm	01
1000mm	02

4.7 MBC14 MULTI BAG CARRIER

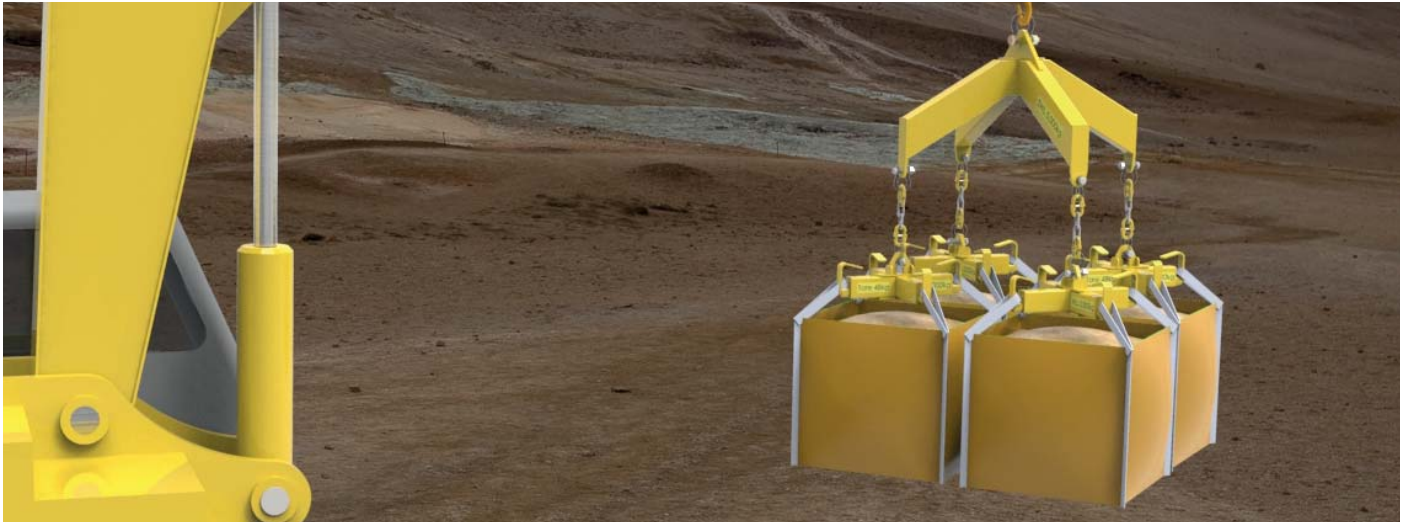

The Thomson Multi Bag Carrier is available in three types: two bag or four bag rigid models and a four bag model with two de-mountable arms for use as either a two or four bag unit.

All models can be supplied with either 600mm or 1000mm Bag Carriers and have a Safe Working Load of 2,000kg per bag.

The Multi Bag Carrier is built for long term use and is fully CE marked and LOLER certified so it meets all the legal requirements.



FEATURES

- Strong and Light
- Two sizes available
- Proven in Use Since 2007
- 2,000 kg WLL per bag
- 4,000 kg Proof Load per bag
- Full Factory Parts Backup
- CE Marked

A QUICK, SIMPLE SOLUTION TO THE HANDLING OF BULK BAGS UP TO 2,000KG.

SPECIFICATIONS

Weight (Four Bag typical)	325 kg
Weight (Two Bag typical)	165 kg
WLL / Bag	2,000 kg
Proof / Bag	4,000 kg
Latches	Spring Operated

Body Colour 08E51 Yellow

DOCUMENTATION

Operator's / Maintenance Manual
LOLER Test Certificate

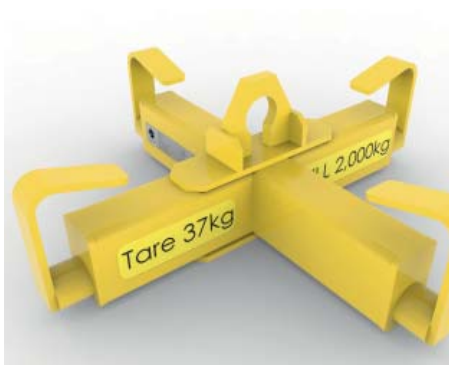

BENEFITS

- Fully certificated and tested.
- Simple to use.
- Light weight.



OPTIONS AND ORDERING INFORMATION

The MBC14 Multi-Bag Carrier is available as a two-bag system, a four bag system or with two bolted legs to allow either two or four bag operation.

The Bag Carriers suspended from the centre beam can be either 600mm or 1000mm types.



Example: MBC14-03-01 Four Leg Beam with two removable legs equipped with 600mm Bag Carriers

PRODUCT ACCEPTANCE

This product is loose lifting tackle and as such no Product Acceptance application has been made

MODEL NUMBERS FOR ORDERING

When ordering this product please use the ordering code below to specify the correct options

MBC14-□□-□□

Main Beam Type	Code
<i>Two Leg</i>	01
<i>Four Leg Fixed</i>	02
<i>2 / 4 Leg</i>	03

Carrier Size	Code
<i>600mm</i>	01
<i>1000mm</i>	02

Section 5: Clipping and De-Clipping

5.1 FC09 MK3 FASTCLIP ATTACHMENT



The Thomson Mk3 Fastclip attachment is the industry standard machine in the UK.

Simple to set and operate, hard to break and simple to service and maintain this machine is always popular with operators.

The machine is equipped with the fastest and simplest to use sleeper lifter in its class.

In the hands of a skilled operator rates of 60 sleepers per minute are regularly achieved on rail stressing work.

The latest models can be specified for 3rd and 4th rail operation.



FEATURES

- Extremely Strong and Robust
- Fully protected hydraulic cylinders
- Simplest machine to set
- Simplest machine to use
- Low operator fatigue
- High reliability
- Long life wear parts
- Wide range of optional extras
- Can be specified for 3rd & 4th rail
- Full Factory Parts Backup
- CE Marked

THE MOST POPULAR MACHINE OF ITS KIND WITH OWNERS AND OPERATORS

SPECIFICATIONS

Weight	2250 kg
Braking System	Fail Safe, 2 wheels
Clipping Mechanism	Fully Hydraulic
De-Clipping	Fully Hydraulic
Sleeper Lifting	Single Control
O/A Height	1,230 mm
O/A Width	2,200 mm
O/A Length	2,195 mm

Max. Hyd. Pressure	210 Bar
Min. Hyd. Pressure	90 Bar
Body Colour	08E51 Yellow
Moving Parts	Signal Red
Handles	White

DOCUMENTATION

- Operator's Manual
- Parts Manual
- Maintenance Plan
- Factory Test Certificate
- Brake Test Certificate
- PADS No. 094/013005



BENEFITS

- Suitable for all RRV's
- Hydraulic pressure control built in and oil cooling option for high speed use
- Low operator fatigue means reliable results



Specifications given may be subject to change due to our policy of continuous improvement

OPTIONS AND ORDERING INFORMATION

The FC09 Mk3 Fastclip Machine is available with either fixed or tipping adapter heads.

The tipping adapter head should be specified where the host machine is fitted with a Miller Bug or Geith Quick Coupler as these types have to be fully crowded under the machine boom in order to release the attachment.

The clipping and de-clipping hydraulic circuits are fitted with hydraulic pressure control as standard.

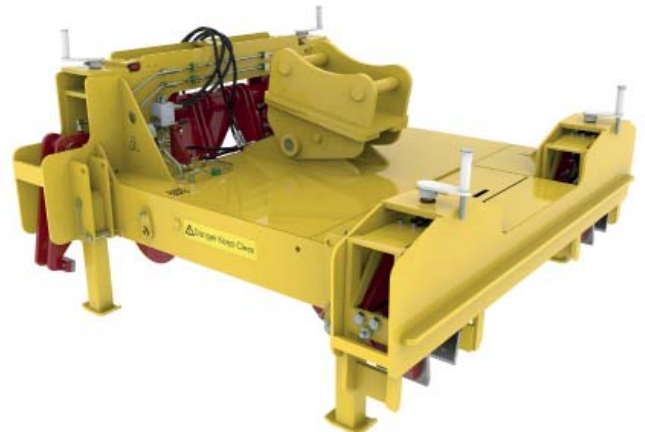

Example: FC09-01 Mk3 Fastclip Machine with fixed adapter head

PRODUCT ACCEPTANCE

This product has full Network Rail Product Acceptance under Certificate number 05/01958

MODEL NUMBERS FOR ORDERING

When ordering this product please use the ordering code below to specify the correct options.

FC09-□□-□□

Adapter Head Type	Code
<i>With Fixed Adapter Head</i>	01
<i>With Tilting Adapter Head</i>	02

Machine Configuration	Code
<i>Standard</i>	01
<i>3rd / 4th Rail</i>	02

NOTE

When ordering this machine we will need to know the adapter head dimensions of your host machine.

Please see Section 10 for details of the dimensions we require for a Type 04 head

5.5 EDC15 E-CLIP DE-CLIPPER



Our E-Clip De-Clipper is the ideal solution for the rapid removal of Pandrol E and PR clips.

Spring loaded hooks snatch out the clips as the machine is propelled along the track.

The machine incorporates fail-safe brakes, automatic marker lights and a hydraulic hook raising mechanism for rail travel.

Adapter heads are available to suit all types of road rail machine.



FEATURES

- Adjustable for rail height and wear
- Twin hydraulic circuit - de-clip one rail or both
- Rubber baffles to prevent clips flying
- Heavy duty construction
- Full range of adapter heads
- Full Factory Parts Backup
- CE Marked

A HEAVY DUTY DEVICE FOR THE RAPID REMOVAL OF PANDROL E AND PR CLIPS.

SPECIFICATIONS(TYPICAL)

Weight	1990 kg
Operating Speed	5 kph
Brake Test Load	125 kg
Mechanism	Hydraulic
O/A Height	1,357mm
O/A Width	1,919mm
O/A Length	2,119mm

Max. Hyd. Pressure	210 Bar
Min. Hyd. Pressure	90 Bar
Body Colour	08E51 Yellow
Moving Parts	Signal Red
Handles	Black / White

DOCUMENTATION

Operator's Manual
Parts Manual
Maintenance Plan
EA Certificate



BENEFITS

- Remove up to 2.5 km of clips per hour
- De-clip one rail or both
- Reduced manpower, increased safety



Specifications given may be subject to change due to our policy of continuous improvement

OPTIONS AND ORDERING INFORMATION

The EDC15 E-Clip De-Clipper is available with either fixed or tipping adapter heads.

The tipping adapter head should be specified where the host machine is fitted with a Miller Bug or Geith Quick Coupler as these types have to be fully crowded under the machine boom in order to release the attachment.

EDC15 E-Clip De-Clippers are fitted with hydraulic pressure control as standard.



Example: EDC15-02 E-Clip De-Clipper with tilting adapter head

PRODUCT ACCEPTANCE

Product Acceptance has been applied for under Application Number PA05/06677



The tipping head allows easier detaching of the De-Clipper with some quick couplers

MODEL NUMBERS FOR ORDERING

When ordering this product please use the ordering code below to specify the correct options.

EDC15-□□

Adapter Head Type	Code
<i>Fixed Adapter Head</i>	01
<i>Tipping Adapter Head</i>	02

NOTE

When ordering this machine we will need to know the adapter head dimensions of your host machine.

Please see Section 10 for details of the dimensions we require for a Type 04 head

Section 6: Signals and Crossings

6.3 SPG16 SIGNAL POST GRAB



The Thomson Signal Post Grab is the ideal solution to handling round posts.

The jaws are lined with specially formulated polyurethane pads which give a high level of grip without damaging the galvanized surface of the post.

Models are available with or without rotators and with fixed or tilt heads.

Models without rotators are ideal for use with excavators equipped with tilt-rotators.

Twin grip cylinders protected against hose failure by pilot operated check valves ensure that the grab is safe in operation.



FEATURES

- Strong and Robust
- Fully protected hydraulic cylinders
- Bronze bushes in jaws
- All Steel Welded Construction
- High Resistance to Dynamic Loads
- High Resistance to Abuse
- Proven in Use Since 2005
- 3,000 kg WLL
- 6,000 kg Proof Load
- Full Factory Parts Backup
- CE Marked

A ROBUST AND VERSATILE GRAB FOR HANDLING SIGNAL POSTS AND STRUCTURES

SPECIFICATIONS

Weight (Grab Only)	400 kg
Pad Coating	Polyurethane
Range of Grip	120 to 250mm diam. or 100 to 450mm diam.
WLL (Safe Working Load)	3,000 kg
Proof Load (Factory Test)	6,000 kg

Max. Hyd. Pressure	210 Bar
Min. Hyd. Pressure	120 Bar
Body Colour	08E51 Yellow
Moving Parts	Signal Red

DOCUMENTATION

Operator's Manual
Parts Manual
Maintenance Plan
LOLER Test Certificate



BENEFITS

- Powerful grip with soft, high friction pads to minimise damage to surface coatings
- High dexterity for accurate and precise placement
- Small size to maximise applications



Specifications given may be subject to change due to our policy of continuous improvement

OPTIONS AND ORDERING INFORMATION

The SPG16 Signal Post Grab has two models: a two-jaw model for posts from 120mm to 250mm diameter and a four jaw model for posts from 100mm to 450mm diameter and also for tapered posts.

Both models can be specified with fixed adapter heads for use with tilt rotators, with a built in rotator and fixed head or with a rotator and tilting head.

Two specifications of tilting head are available: a compact 30 degree tilt head or the larger 60 degree tilt head.



Example: SPG16-01-02 Two-Jaw Signal Post Grab with rotator and fixed 2-pin head

PRODUCT ACCEPTANCE

No application has been made for Product Acceptance on this grab to date.

Thomson Engineering Design will be pleased to apply for Product Acceptance if required

MODEL NUMBERS FOR ORDERING

When ordering this product please use the ordering code below to specify the correct options

SPG16-□□-□□

Grab Type	Code
<i>Two Jaw</i>	01
<i>Four Jaw</i>	02

Adapter Type	Code
<i>Fixed 2-Pin Adapter Head</i>	01
<i>Rotator and Fixed 2-Pin Head</i>	02
<i>Rotator and 30° Tilt 2-Pin Head</i>	03
<i>Rotator and 60° Tilt 2-Pin Head</i>	04

NOTE

When ordering this product we will need to know the dimensions specified in Section 10 for a Type 04 adapter

6.8 SPC09 SIGNAL POST CRANE



The Thomson Signal Post Crane makes light work of changing coloured light signal heads, junction indicators and associated equipment.

The crane is made in 1.8m and 0.9m sections which fit together and clamp to the signal post and which can cater for any signal post height.

A high quality certificated hand winch is used to lower the old signal head to the ground and to raise the new one.

The entire structure of the crane is made of a light weight aluminium alloy for ease of carrying.



FEATURES

- Strong and Light
- Sectional Design
- Proven in Use Since 2004
- 125 kg WLL
- 250 kg Proof Load
- Full Factory Parts Backup
- CE Marked

A QUICK, SIMPLE SOLUTION TO HANDLING OF HEAVY SIGNAL HEADS AND ASSOCIATED EQUIPMENT

SPECIFICATIONS

Weight (Complete 7m)	60 kg
Weight (Heaviest Section)	14 kg
WLL (Safe Working Load)	125 kg
Proof Load (Factory test)	250 kg
Mechanism	Hand winch

APPLICATIONS

Signal Heads
Junction Indicators

DOCUMENTATION

Operator's / Maintenance Manual
LOLER Test Certificate
PADS No. 094/019176



BENEFITS

- Fully certificated and tested
- Simple set-up & operation
- Light weight



OPTIONS AND ORDERING INFORMATION

The SPC09 Signal Post Crane is available in plain and anodised finishes.

The set of parts includes:

- Winch on 1800mm post with jib
- 2 x 1800mm extension posts
- 1 x 900mm extension post
- 1 x Base
- 3 x Clamp assemblies

PRODUCT ACCEPTANCE

This product has full Network Rail Product Acceptance under Certificate number 05/03126



SPC09-01 Signal Post Crane assembly

MODEL NUMBERS FOR ORDERING

When ordering this product please use the ordering code below to specify the correct options

SPC09-□□

Grab Type	Code
<i>Plain Finish</i>	01
<i>Anodised Finish</i>	02

6.9 CSL16 CROSSING SLAB LIFTER

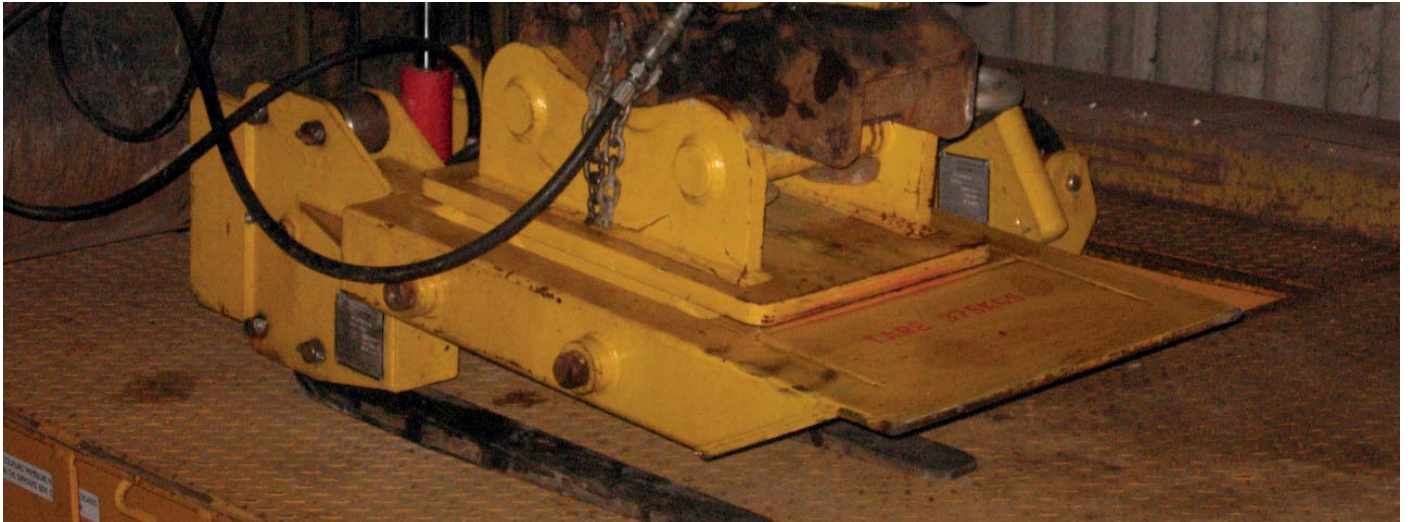

The Thomson Crossing Slab Lifter is designed for the rapid removal and replacement of rubber block level crossings.

The forks hydraulically clamp the crossing slab into the device so that slabs can be stacked on edge and retrieved easily.

When replacing crossing slabs the side and front blades are used to press the slabs firmly into position.

One operator with two men to release the tie rods can remove a two lane crossing entirely in around thirty minutes.



FEATURES

- Strong and Robust
- Fully protected hydraulic cylinders
- Bronze bushes in jaw rollers
- All Steel Welded Construction
- Forged forks
- High Resistance to Dynamic Loads
- High Resistance to Abuse
- Proven in Use Since 2005
- 3,000 kg WLL
- 6,000 kg Proof Load
- Full Factory Parts Backup
- CE Marked

A SAFE AND QUICK WAY TO REMOVE AND INSTALL LEVEL CROSSING SLABS MINIMISING LABOUR AND MAXIMISING SAFETY

SPECIFICATIONS

Weight (Grab Only)	400 kg	Max. Hyd. Pressure	210 Bar
Pad Coating	Polyurethane	Min. Hyd. Pressure	120 Bar
Range of Grip	90 to 300mm diam.	Body Colour	08E51 Yellow
WLL (Safe Working Load)	3,000 kg	Moving Parts	Signal Red
Proof Load (Factory Test)	6,000 kg		

DOCUMENTATION

Operator's Manual
Parts Manual
Maintenance Plan
LOLER Test Certificate
PADS No, 094/012065



BENEFITS

- High dexterity for accurate and precise placement
- Small size to maximise applications
- Press blades for installing crossings



Specifications given may be subject to change due to our policy of continuous improvement

OPTIONS AND ORDERING INFORMATION

The CSL16 Crossing Slab Lifter is available with a fixed 2-pin head, a rotator and fixed 2-pin head or with a rotator and tilting 2-pin head.

The tilting head tilts to 30 degrees in either direction.

The design incorporates blades on the front and rear of the device for pressing the slabs into place between the rails.

A pressure control valve is fitted as standard.

A transport / storage stillage is available for this product.



PRODUCT ACCEPTANCE

This product has full Network Rail Product Acceptance under Certificate number 05/04271

Example: CSL16-01-01 Crossing Slab Lifter with fixed head and no stillage

MODEL NUMBERS FOR ORDERING

When ordering this product please use the ordering code below to specify the correct options

CSL16-□□-□□

Grab Type	Code
<i>Fixed Head</i>	01
<i>Rotator and Fixed Head</i>	02
<i>Rotator and Tilting Head</i>	03

Stillage	Code
<i>No Stillage</i>	01
<i>With Transport / Storage Stillage</i>	02

NOTE

When ordering this product we will need to know the dimensions specified in Section 10 for a Type 04 adapter

Section 7: Cable and Electrification

7.1 CHY10 CABLE HANDLING YOKE



The Thomson Cable Handling Yoke is the most efficient way to handle cable drums and to lay cable using an excavator crane.

By withdrawing two retaining pins the drum shaft is released from the Yoke.

Fit the drum shaft to the cable drum and pick it up with the Yoke. Lock the retaining pins and you are ready to lay the cable.

The Yoke can even be fitted with a hydraulic rotator to help position the drum when used just for drum handling. Can be made to suit any range of drum sizes and weights.



Rotator Version

SPECIFICATIONS (STD.)

Weight (typical)	145 kg
Shaft Diameter	80 mm
Max. Drum Width	1,200 mm
WWL (Safe Working Load)	3,000 kg
Proof Load (Factory Test)	6,000 kg

Max. Hyd. Pressure	210 Bar
Min. Hyd. Pressure	50 Bar
Body Colour	08E51 Yellow

FEATURES

- Strong and Robust
- Very quick and simple to use
- All Steel Welded Construction
- High Resistance to Dynamic Loads
- High Resistance to Abuse
- Versions for any range of drum sizes and weights can be supplied
- 3,000 kg WLL
- 6,000 kg Proof Load
- Full Factory Parts Backup
- CE Marked

A REALLY EASY TO USE AND QUICK SOLUTION TO CABLE LAYING

DOCUMENTATION

- Operator's Manual
- Parts Manual
- Maintenance Plan
- LOLER Test Certificate

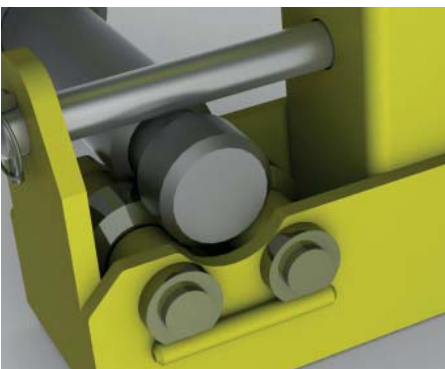

BENEFITS

- Minimises handling time
- Maximises productivity
- High reliability through robust construction



OPTIONS AND ORDERING INFORMATION

The CHY10 Cable Handling Yoke comes in two standard sizes but can be made to any other size as a special order.

Size 01 can cope with drums up to 1.8m diameter x 1m wide and weighing up to 2 tonnes.

Size 02 can cope with drums up to 2.4m diameter x 1.5m wide weighing up to 4.5 tonnes



Example: CHY10-02-01 Cable Yoke for 2.4m diameter x 1.5m wide drums with one shaft and collar set

PRODUCT ACCEPTANCE

No application has been made for Product Acceptance in respect of this product.

MODEL NUMBERS FOR ORDERING

When ordering this product please use the ordering code below to specify the correct options

CHY10-□□-□□-□

Capacity	Code
Size 01 (1.8m x 1.0m)	01
Size 02 (2.4m x 1.5m)	02
Custom Size	03

No. of Shaft Assemblies	Code
1 Shaft and Collar set	01
2 Shaft and Collar sets	02

Etc.

Mounting	Code
Shackle for hook	S
Rotator and adapter	R

NOTE

When ordering custom sized Cable Yokes please specify the maximum dimensions and weight of the drums to be handled together with the required drum shaft diameter

NOTE

When ordering Cable Yokes with rotator please see Section 10 for details of adapter heads

7.2 CY16 DUAL CABLE HANDLING YOKE



The Thomson CY16 Dual Cable Handling Yoke is a rapid, simple and efficient way to handle cable drums and to lay cable using an excavator or RRV.

By withdrawing two retaining pins the drum shaft is released from the Dual Yoke.

Fit the drum shaft to the cable drum and pick it up with the Dual Yoke. Lock the retaining pins and you are ready to lay the cable.

The Dual Yoke is supplied with free running shafts as standard but can also be supplied with braked shafts for tensioning cables as they are laid.

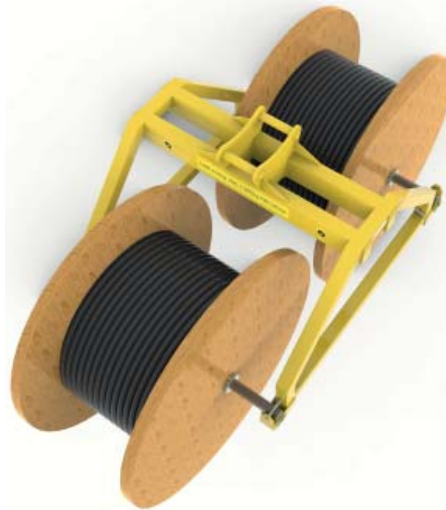

Body Colour 08E51 Yellow

SPECIFICATIONS (STD.)

Weight (typical)	750 kg
Shaft Diameter	80 mm
Max. Drum Width	1,400 mm
Max Drum Diameter	2,000 mm
WWL (Safe Working Load)	3,000 kg
WWL per drum	1,500 kg
Proof Load (Factory Test)	6,000 kg



FEATURES

- Strong and Robust
- Very quick and simple to use
- All Steel Welded Construction
- High Resistance to Dynamic Loads
- High Resistance to Abuse
- Versions for any range of drum sizes and weights can be supplied
- 3,000 kg WLL
- 6,000 kg Proof Load
- Full Factory Parts Backup
- CE Marked

A REALLY EASY TO USE AND QUICK SOLUTION TO CABLE LAYING

DOCUMENTATION

Operator's Manual
Parts Manual
Maintenance Plan
LOLER Test Certificate

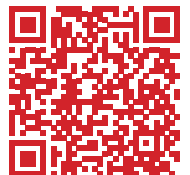

BENEFITS

- Minimises handling time
- Maximises productivity
- High reliability through robust construction

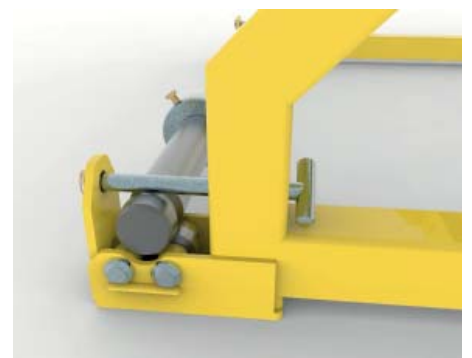

Specifications given may be subject to change due to our policy of continuous improvement

OPTIONS AND ORDERING INFORMATION

The CHY16 Dual Cable Handling Yoke comes in either free running or braked versions.

Both versions can cope with drums up to 2.0m diameter and 1.4m wide.

As standard the device is fitted with 80mm shafts but other sizes may be specified as required.



Example: CY16-01-01 Dual Cable Yoke with one set of 80mm free running shafts

PRODUCT ACCEPTANCE

No application has been made for Product Acceptance in respect of this product.

MODEL NUMBERS FOR ORDERING

When ordering this product please use the ordering code below to specify the correct options

CY16-□□-□□

Shaft Type	Code
Free running 80mm shafts	01
Braked 80mm shafts	02
Custom specification	03

No. of Shaft Assemblies	Code
1 Shaft and Collar set	01
2 Shaft and Collar sets	02

Etc.

NOTE

When ordering custom sized cable yokes please specify the maximum dimensions and weight of the drums to be handled together with the required drum shaft diameter

NOTE

When ordering this product we will need to know the adapter head dimensions for a Type 04 Adapter Head (See Section 10)

7.4 CT06 CABLE THIMBLES

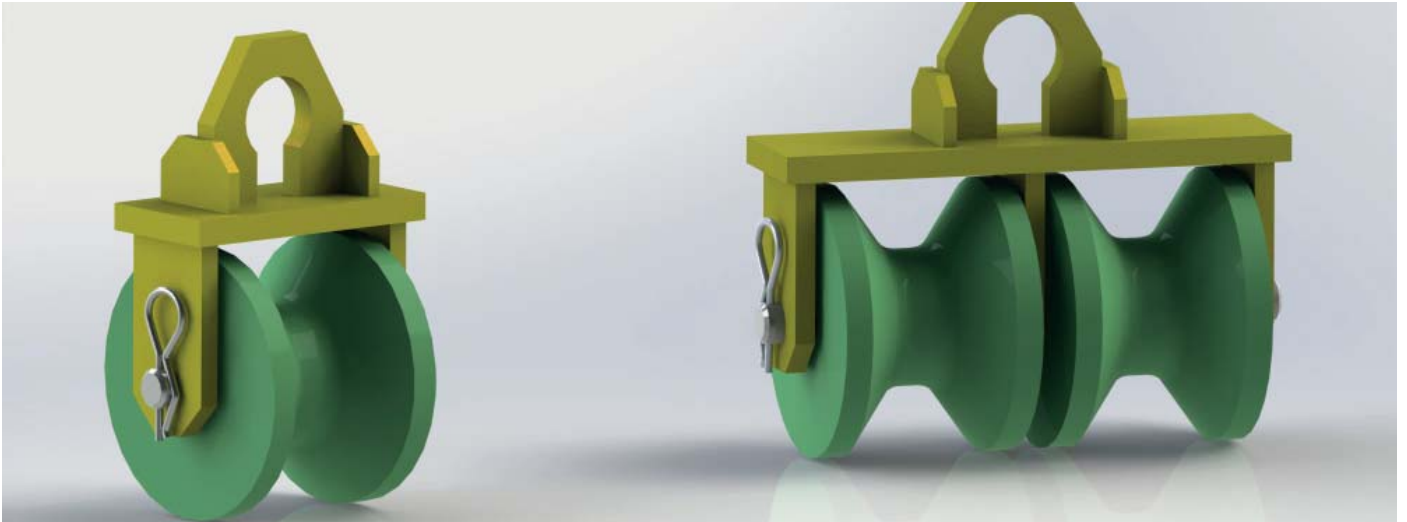

Thompson Cable Thimbles are designed to be suspended from the lifting hook of an excavator crane to guide the cable off the drum.

A soft polyurethane roller running on low friction bearings ensures that the cable is carefully handled.

To disconnect the thimble without cutting the cable the roller can be easily removed from the frame.

Single, twin and multiple roller versions are available to order.

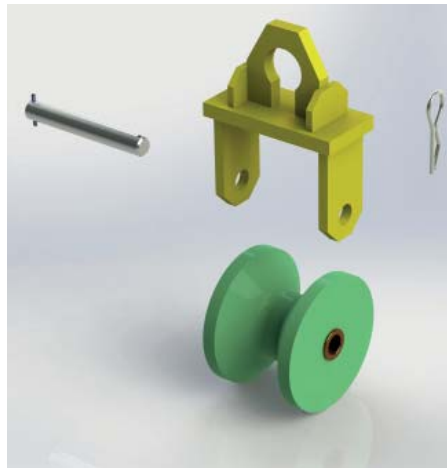

FEATURES

- Strong and Light
- Designed to protect cable
- Soft urethane rollers
- 30 kg WLL
- 45 kg Proof Load
- Full Factory Parts Backup
- CE Marked

A SIMPLE WAY TO REDUCE THE HARD WORK OF CABLE INSTALLATION

SPECIFICATIONS

Weight (Single)	11 kg
Weight (Twin)	14 kg
WLL (Safe Working Load /cable)	30 kg
Proof Load (Factory Test)	45 kg

APPLICATIONS

Signal Cables
Optical Fibre Cables
Power Cables

DOCUMENTATION

Operator's / Maintenance Manual
LOLER Test Certificate

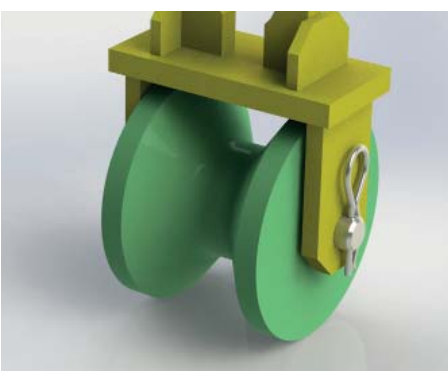

BENEFITS

- Fully certificated and tested
- Simple to use
- Light weight
- Low rolling resistance

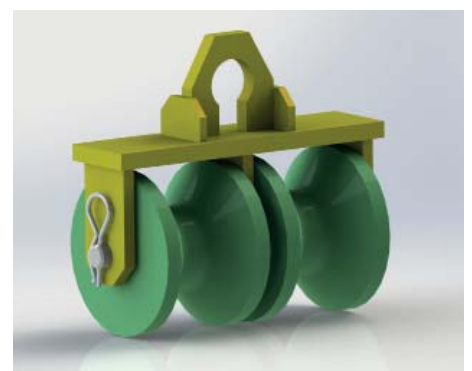

OPTIONS AND ORDERING INFORMATION

The CT06 Cable Thimble is available in single reel and twin reel versions.

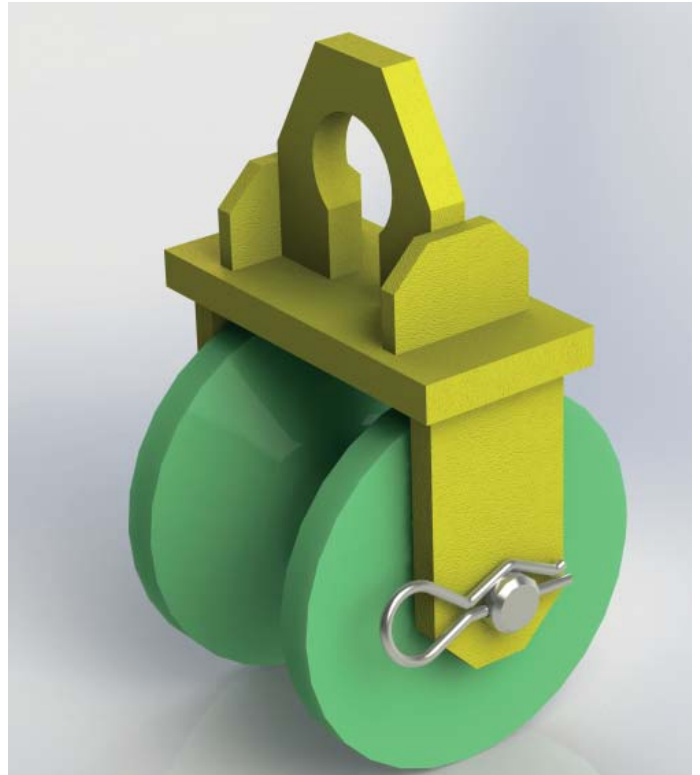

Example: CT06-01 Single Cable Reel

PRODUCT ACCEPTANCE

This product is loose lifting tackle and Product Acceptance is not therefore required

MODEL NUMBERS FOR ORDERING

When ordering this product please use the ordering code below to specify the correct options

CT06-□□

Type	Code
Single Reel	01
Twin Reel	02
Multiple Reels	03

NOTE

When ordering Cable Thimbles with multiple reels please state the number of reels required

7.6 SM15 STEEL SECTION MANIPULATOR



The SM15-01 is purpose designed for the handling, erection and installation of steel masts for track electrification.

Combining a scissor grab with hydraulically telescoping legs, the load is gripped on all four faces using soft urethane pads preventing damage to galvanised surfaces.

High grip force ensures safe handling and a roto-tilt adapter head allows precise positioning for accurate placement onto bolted flanges, tube piles, etc.

A unique pendulum valve which can only be overridden by the banksman from outside the cab ensures safety.



FEATURES

- Powered rotation in all directions
- Dual man pendulum safety release
- Soft contact pads
- High grip force
- High torque worm rotator
- Dual cylinder tilt function
- Check valves on all grip cylinders
- Single man operation in horizontal position for easy mast selection
- Full Factory Parts Backup
- CE Marked
- LOLER certificate supplied

A FAST, SAFE AND EASY WAY TO INSTALL STEEL MASTS ONTO PILES AND BOLTED BASES

SPECIFICATIONS

Weight (typical)	1,400 kg
WLL (Safe Working Load)	3,750 kg
Min. Load Section	200mm x 200mm
Max. Load Section	650mm x 650mm
Head Tilt	+/- 30 degrees
Application:	Square, Rectangular I-Beam & Fabricated Sections

Rotator Circuit

Max. Hyd. Pressure	120 Bar
Min. Hyd. Pressure	90 Bar

Grab Circuit

Max. Hyd. Pressure	210 Bar
Min. Hyd. Pressure	110 Bar

Tilt Circuit

Max. Hyd. Pressure	210 Bar
Min. Hyd. Pressure	90 Bar

Body Colour	08E51 Yellow
Moving Parts	Signal Red

DOCUMENTATION

- Operator's Manual
- Parts Manual
- Maintenance Plan
- Factory Test Certificate
- LOLER Certificate

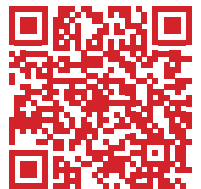

BENEFITS

- Higher output
- Improved Safety
- Precision Installation
- Dual-Man load release



Specifications given may be subject to change due to our policy of continuous improvement

OPTIONS AND ORDERING INFORMATION

The SM15 Steel Section Manipulator is available in three configurations.

- A hydraulic rotator and 60 degree tilt head.
- A hydraulic rotator and 30 degree tilt head.
- A fixed head configuration for use with tilt rotators.
- A transport / storage stillage is also available for this product.



Example: SM15-01-02 Steel Section Manipulator with 60° Tilt Head and Transport / Storage Stillage

PRODUCT ACCEPTANCE

Product Acceptance has been applied for and is currently operating under trial Certificate number PA05/06553

MODEL NUMBERS FOR ORDERING

When ordering this product please use the ordering code below to specify the correct options

SM15-□□-□□

Manipulator Type	Code
<i>With Rotator and 60° Tilt Head</i>	01
<i>With Rotator and 30° Tilt Head</i>	02
<i>With Fixed Adapter Head</i>	03

Stillage	Code
<i>No Stillage</i>	01
<i>With Stillage</i>	02

NOTE

When ordering this product we will need to know the adapter head dimensions for a Type 04 Adapter Head (See Section 10)

7.7 TPH16 TUBE PILE HANDLER

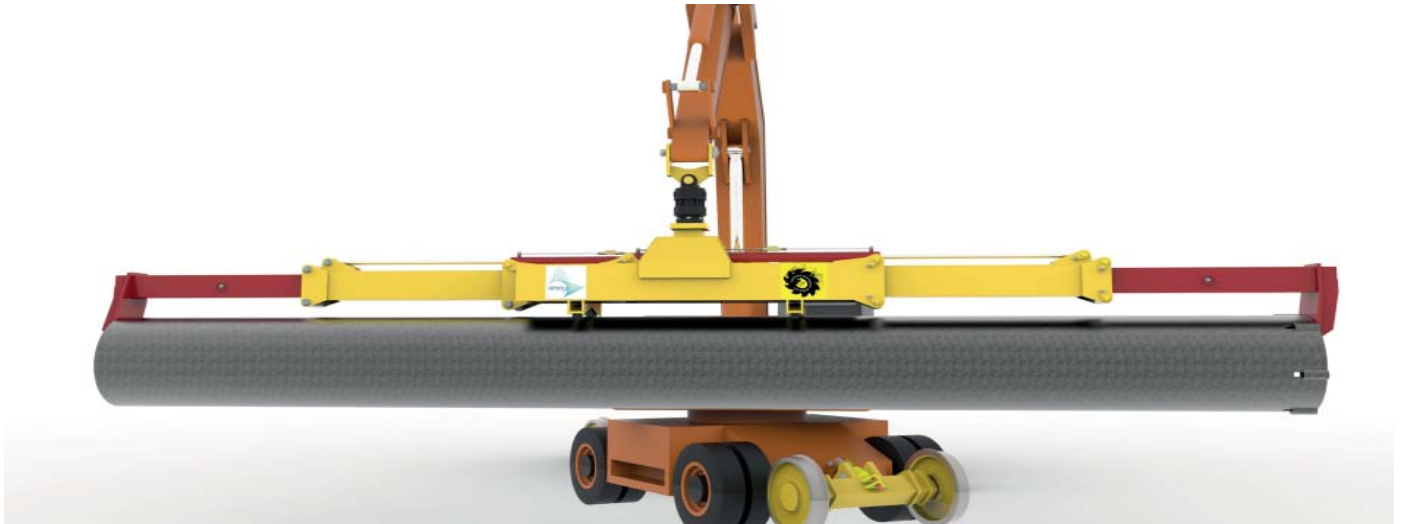

Thomson Tube Pile Handlers are designed for loading, unloading, handling and stacking of tube piles from 3m to 8m in length.

As standard the device incorporates a load levelling function and a heavy duty rotator for simple, safe operation.

Supplied with a custom made transport stillage and an adapter head to suit your host machine this attachment is ready to use on delivery.

The Tube Pile Handler removes the need for men to climb onto the stack of piles to attach or detach chains improving speed and safety.



FEATURES

- Strong and Robust
- Load Levelling feature
- Heavy Duty Rotator
- Full Range of Adapter Heads
- All Steel Welded Construction
- High Resistance to Dynamic Loads
- High Resistance to Abuse
- CE Marked

RAPID, SAFE AND ECONOMICAL WAY OF HANDLING STEEL TUBE PILES IN YARDS AND ON WORK SITES

SPECIFICATIONS (STD.)

Weight	2,250 kg
WLL (Safe Working Load)	2,500 kg
Finish	Powder Coated
Max. Pile Length	8 m
Min. Pile Length	3 m

Max. Hyd. Pressure	210 Bar
Min. Hyd. Pressure	90 Bar

Body Colour	08E51 Yellow
Moving Parts	Signal Red

DOCUMENTATION

LOLER Test Certificate
Operating and Maintenance Instructions



BENEFITS

Standard and Custom designs to suit your exact requirements

Full technical documentation and test reports available



OPTIONS AND ORDERING INFORMATION

The TPH16 Tube Pile Handler comes with a transport / storage stillage as standard.

This product is available with our full range of adapter head systems.

Automatic changeover from grab function to load levelling function is fitted as standard.



Example: TPH16-04 Tube Pile Handler with stillage, rotator and two-pin adapter head

PRODUCT ACCEPTANCE

This product is intended for use in handling yards and no application has been made for Product Acceptance

MODEL NUMBERS FOR ORDERING

When ordering this product please use the ordering code below to specify the correct options

TPH16-□□

Adapter Type	Code
<i>Pile Handler with flange only</i>	00
<i>Fixed head for swivel hook</i>	01
<i>Swivel head for fixed hook</i>	02
<i>Rotator + 1 pin head</i>	03
<i>Rotator + 2 pin head</i>	04
<i>Archimedes / QC adapter head</i>	05
<i>Rotator + truck crane adapter</i>	06
<i>Special Adapter</i>	07

NOTE

When ordering adapter heads we will need to know the dimensions of your host machine.

Please see Section 10 for details of the dimensions we require for each type of adapter head.

7.8 SPL16 STOVEPIPE LIFTER



The Stovepipe Lifter, makes light work of positioning and fitting stovepipes and dropper tubes to tunnel roofs and gantry structures.

The device incorporates a telescopic carriage making it suitable for 1m to 5m long steel.

A hand operated hydraulic lift allows the installers to complete the lifting operation with high precision - effectively eliminating the risk of the excavator damaging the structure.

The specially designed clamps allow plenty of lateral movement and free rotation of the steel to when aligning bolted flanges.

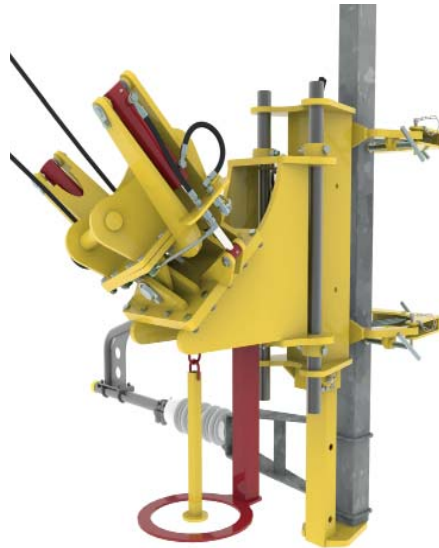

FEATURES

- Strong and Robust
- Hand Operated Lifting Feature
- Heavy Duty Construction
- Full Range of Adapter Heads
- Tilt Heads Available
- Pendulum Level Indicator Available
- All Steel Welded Construction
- High Resistance to Dynamic Loads
- High Resistance to Abuse
- Transport Stillage Available
- CE Marked

RAPID, SAFE AND ECONOMICAL WAY OF INSTALLING STOVEPIPES AND DROPPER TUBES.

SPECIFICATIONS (STD.)

Weight	515 kg
WLL (Safe Working load)	350 kg
Finish	Powder Coated
Max. Pipe Length	5 m
Min. Pipe Length	1 m

System Hyd. Pressure 150 Bar
(300 Bar wth Pressure Reducing Valve Option)

Body Colour 08E51 Yellow

DOCUMENTATION

LOLER Test Certificate
Operating and Maintenance Instructions



BENEFITS

Standard and Custom designs to suit your exact requirements

Precision installation

Component stillages available (contact factory for details)



OPTIONS AND ORDERING INFORMATION

The SPL16 Stovepipe Lifter has bolt-on interchangeable jaws.

The small standard jaws are suitable for round posts up to 100mm diameter or square posts up to 70mm.

The larger standard jaws can cope with round posts up to 150mm diameter and square posts up to 120mm.

Extra large jaws can cope with round posts up to 250mm diameter and square posts up to 200mm.

A full range of adapter heads is available and a tilt base can also be specified - fitted between the adapter head and the frame of the device for total control over alignment. When specifying the tilting adapter head option a pressure reducing valve (PR) may be specified when the system pressure of the host machine exceeds 150 Bar.

A transport / storage stillage is available for this product.



Example: SPL16-02-02-01 Stovepipe Installer with Tilting Adapter Head (without PR valve) and Pendulum Level Indicator but with no Transport / Storage Stillage

PRODUCT ACCEPTANCE

No application has been made for Network Product Acceptance to date however Thomson Engineering Design will be pleased to make an application if required

MODEL NUMBERS FOR ORDERING

When ordering this product please use the ordering code below to specify the correct options

SPL16-□□-□□-□□

Jaw Sets	Code
Fixed Adapter Head	01
Tilting Adapter Head	02
Tilting head with PR valve	03

Level Indicator	Code
No indicator	01
With Pendulum Level indicator	02

Stillage	Code
No stillage	01
With Transport / Storage Stillage	02

NOTE

When ordering this product we will need to know the adapter head dimensions for a Type 04 Adapter Head (See Section 10)

7.9 TDS16 DELIVERY STILLAGES

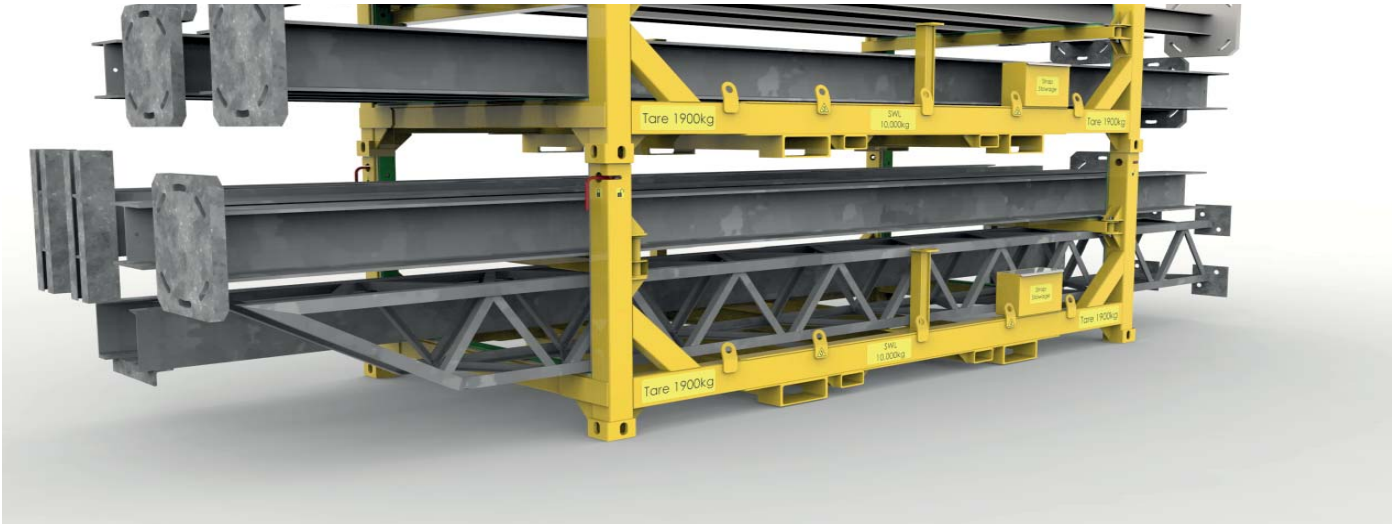

Thomson Engineering Design manufactures a range of specialised stillages for storing and transporting electrification components.

Stillages are made to order so we can tailor the design to your exact requirements.

Unique urethane linings can be fitted to eliminate the risk of damage to surface coatings.

Stillages can be made to ISO container dimensions or custom dimensions.



SPECIFICATIONS (MAX.)

Weight	4,000 kg
WLL (Safe Working Load)	15,000 kg
Finish	Powder Coated
Max Length	6 m
Max Height	2.5m

Standard Colour 08E51 Yellow



FEATURES

- Strong and Robust
- Custom Designs
- Full Documentation
- All Steel Welded Construction
- High Resistance to Dynamic Loads
- High Resistance to Abuse
- CE Marked

ECONOMICAL SOLUTION TO MATERIALS HANDLING

DOCUMENTATION

Load Test Certificate
 Operating and Maintenance Instructions
 PADS No. 094/016209



BENEFITS

- Standard and Custom designs to suit your exact requirements
- Range of accessories available
- Full technical documentation and design reports available



OPTIONS AND ORDERING INFORMATION

Thomson TDS16 delivery stillages are designed to fit either ISO twist lock or Philmor trailer twist lock locations.

The standard stillage is specifically designed for the haulage and delivery of electrification mast fabrications. It incorporates urethane padding and tie down points to prevent damage to galvanised masts and components.

Additional equipment can be specified to adapt the stillage for carrying cantilevers.



Example: TDS16-01 Standard Mast Stillage for Philmor Trailers

PRODUCT ACCEPTANCE

Electrification Mast Stillage has been granted full Network Rail Product Acceptance under Certificate number PA05/06355

MODEL NUMBERS FOR ORDERING

When ordering this product please use the ordering code below to specify the correct options

TDS16-□□

Fitting	Code
<i>Philmor Trailer</i>	01
<i>ISO Twist Locks</i>	02
<i>Custom Size</i>	03

NOTE

Please contact the factory for details of optional extra equipment.

Section 8: Miscellaneous Equipment

8.4 ETS10 ELK TROLLEY SKATE

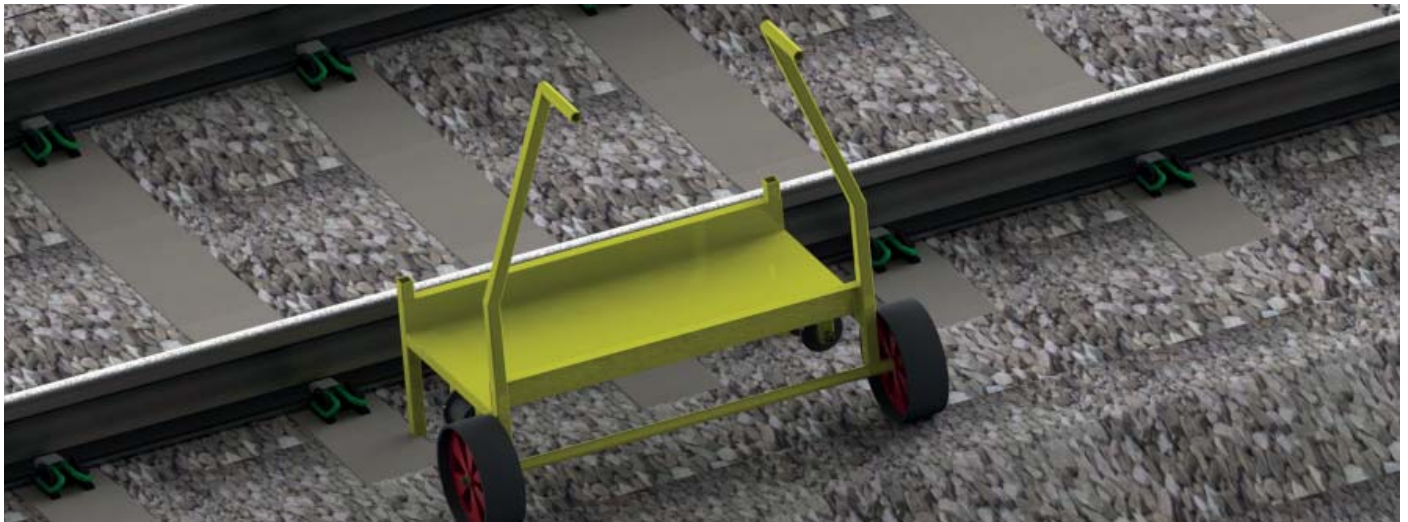

Carry your tools and equipment right from the van to the track and then along the line to the worksite on a single trolley - the Elk Trolley Skate.

On the rail the Elk Trolley Skate runs on hard nylon wheels with sealed ball races to make light work of propelling even the heaviest loads.

Off the rail the Elk Trolley Skate runs on either solid rubber or pneumatic tyres.

With removable handles this skate is easy to stow on a vehicle and the load tray is large enough to carry tools, bars, gas cylinders, etc.

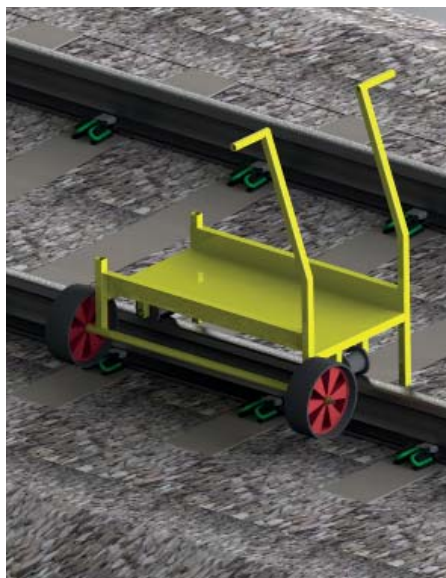

FEATURES

- Strong and Robust
- Unique Road / Rail design
- Removable Handles
- Strong steel construction
- 250kg capacity
- Full Factory Parts Backup
- CE Marked

AN EXTREMELY USEFUL ADDITION TO ANY TRACK WORK GANG'S INVENTORY

SPECIFICATIONS

Weight	24 kg
WLL (Safe Working Load)	250 kg
Proof Load (Factory test)	500 kg

Wheels Plastic centre/urethane tyre

Body Colour 08E51 Yellow
Wheels Red

Deck Height (above rail)	225 mm
Tray Width	450mm
Tray Length	900 mm



BENEFITS

- Dual Purpose Device - road and rail
- Carry heavy tools and equipment right from the van to the job on one trolley
- Light and compact for transport



OPTIONS AND ORDERING INFORMATION

The ETS10 Elk Trolley Skate is available either with an open ended deck or a closed ended deck.

Both models feature removable handles, solid rubber tyred wheels and hard plastic rail wheels on ball bearing races.

A special version is also available with racking to hold 18 Instant Barrier Posts (see page 110).



Example: ETS10-01 Trolley Skate with open ended deck

PRODUCT ACCEPTANCE

No application has been made for Network Rail Product Acceptance in relation to this product

MODEL NUMBERS FOR ORDERING

When ordering this product please use the order code below to specify the correct model

ETS10-□□

Trolley Skate Type	Code
<i>Open Ended Deck</i>	01
<i>Closed Ended Deck</i>	02
<i>For Barrier Posts</i>	03

8.6 RMT13 RAIL MARKING / GREASING TROLLEY



The Thomson Rail Marking / Greasing Trolley is a unique device designed for painting a mark or applying grease along the head of the rail.

Track Lube is often necessary on tight radius curves to prevent excessive wheel flange wear. This device accurately applies grease exactly where it is needed without waste or hardship on the operator.

The device can also apply a paint line to the head of the rail to demarcate work zones or areas where particular hazards exist.



FEATURES

- Strong and robust
- Lightweight construction
- Adjustable for all can sizes
- Long life Delrin wheels
- Ball race wheel bearings
- Side push handle with spray control
- Quick to assemble and dismantle
- For spraying paint or grease
- Full Factory Parts Backup
- CE Marked

A QUICK AND EASY WAY TO MARK OUT WORK AREAS OR TO APPLY TRACK LUBE.

SPECIFICATIONS(TYPICAL)

Weight (complete unladen)	12 kg
Weight (heaviest part)	9.5kg
Load Capacity	50 kg
Capacity (600ml Cans)	24 cans
Handle Height (above rail)	680 mm
O/A Width	1,000 mm
O/A Length	1,000 mm
O/A height (assembled)	800 mm

Body Colour	Yellow
Construction	Aluminium Alloy
Usage	Paint / Grease
Min. can length	120 mm
Max. can length	350 mm*

*note: longer cans can be accommodated using optional high capacity model.

DOCUMENTATION

Operator's Manual
Parts Manual
Maintenance Plan
Certificate of Conformity
PADS No. 094/001800



BENEFITS

- Quick, Simple and Accurate
- Reliable, durable marking
- Accurate grease placement
- Reduced manpower requirement
- Clear demarcation of track zones

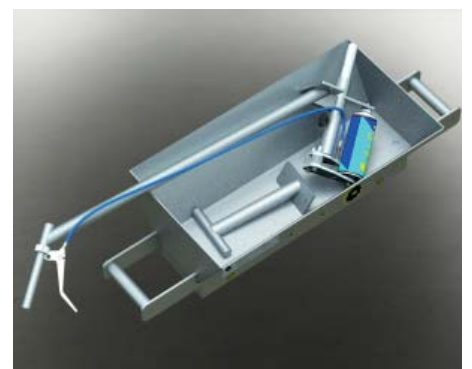

Specifications given may be subject to change due to our policy of continuous improvement

OPTIONS AND ORDERING INFORMATION

The RMT13 Rail Marking / Greasing Trolley is available in two models: standard and high capacity.

The frame and bin are powder coated in yellow, the handle and can holder in white.

Hard plastic rail wheels are fitted and these run on ball bearings.



PRODUCT ACCEPTANCE

This product has full Network Rail Product Acceptance under Certificate number 05/05945

Example: RMT13-01 Rail Marking / Greasing Trolley

MODEL NUMBERS FOR ORDERING

When ordering this product please use order code

RMT13-□□

Body Type	Code
<i>Standard</i>	01
<i>High Capacity</i>	02

8.7 TB14 TOW BARS, LINKS AND ADAPTERS

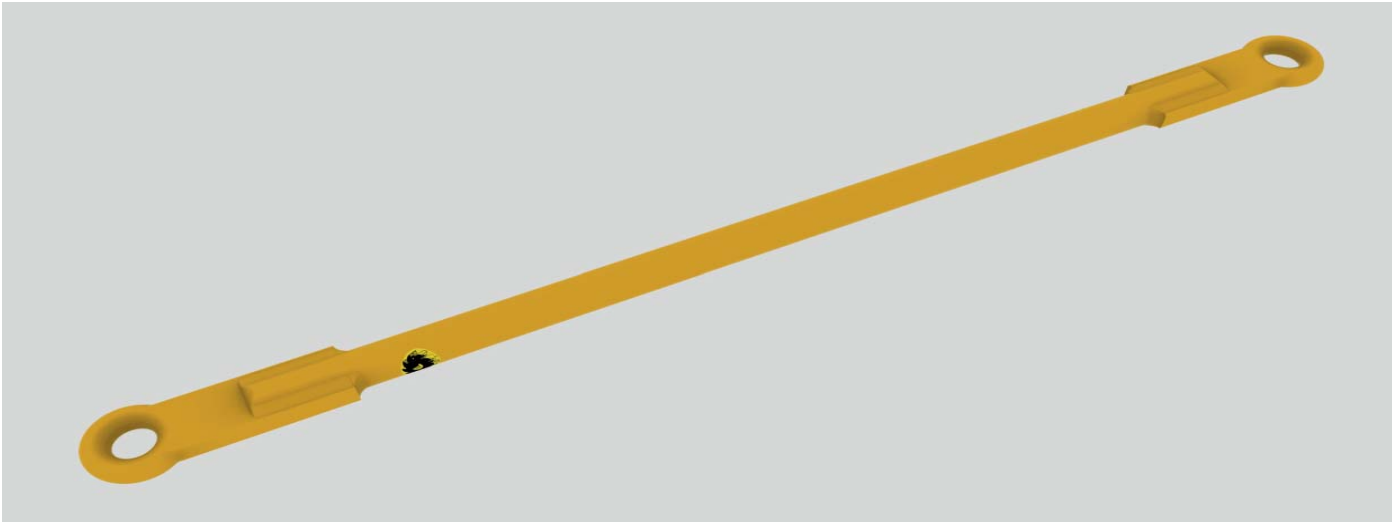

Thompson Tow Bars are made to order allowing us to custom make tow bars to your specifications.

Our standard design is a 2m long bar with forged eyes welded to a high tensile steel centre bar however, custom built tow bars for special purposes are frequently produced.

Extra features such as pipe and cable brackets can easily be accommodated and special light-weight designs and extra long lengths are available.

The specifications on this page are for our standard tow bar. Please contact us for other options.



FEATURES

- Strong and Robust
- Custom designs available
- Forged eyes
- All Steel Welded Construction
- High Resistance to Dynamic Loads
- High Resistance to Abuse
- CE Marked

HIGH STRENGTH AND ECONOMICAL
TOW BAR FOR EMERGENCY RECOVERY
AND GENERAL APPLICATIONS

SPECIFICATIONS (STD.)

Weight	42 kg
Finish	Powder Coated
Length (pin centres)	2,000mm
Max. Tow Force	160 kN
Proof Load (Factory Test)	200 kN

Options available include:

- Lightweight construction
- Cranked design
- Hose and cable mounts
- Carrying handles
- Adapter links
- Stowage brackets

DOCUMENTATION

Test Certificate

Design Validation Report (if required)

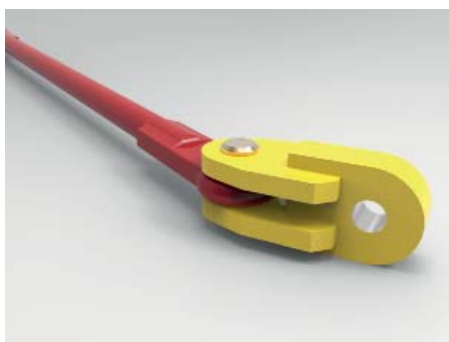

BENEFITS

Standard and Custom designs to suit your exact requirements

Full technical documentation and test reports available



OPTIONS AND ORDERING INFORMATION

Thomson TB14 Tow Bars come in two basic designs: solid centre bars and lighter tubular bars.

Forged towing eyes are fitted to both ends of standard tow-bars and both designs meet the requirements of RIS1530-plt for emergency recovery use.

Tow bars are available in lengths from 1m to 5m.



Example: TB14-01-02 Solid Bar Tow-bar 2m long

PRODUCT ACCEPTANCE

This product is designed to RIS1530-plt but, due to the wide variance of designs, has not been presented for Network Rail Product Acceptance

MODEL NUMBERS FOR ORDERING

When ordering this product please use the ordering code below to specify the correct options

TB14-□□-□□-□

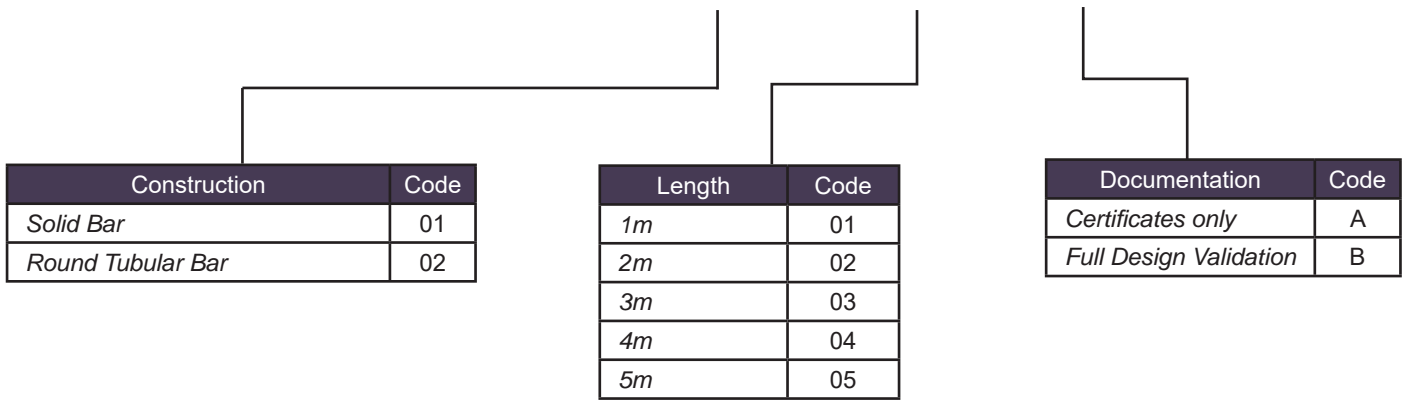

NOTE

Non-standard configurations such as linked ends and tow-bars with different end fittings are available to special order

Please contact the factory for further details

8.8 RB11 LIGHTWEIGHT ROLLER BEDS



Lightweight roller beds are the solution to moving loads in tunnels, on platforms and in other areas where access is too restricted for machines.

Two sizes are available, single and double roller width. Both feature a high strength, high rigidity aluminium alloy space frame with removable rollers.

The rollers have thick walled aluminium outer tubes running on sealed for life ball races and high tensile steel tubular shafts. The result is a low friction, high capacity roller set.



FEATURES

- Light and compact
- Rollers removable for further weight reduction
- High load capacity
- Low friction
- All Aluminium Welded Construction frame
- High Resistance to Dynamic Loads
- High Resistance to Abuse
- CE Marked

A ROBUST, SAFE AND RELIABLE SYSTEM FOR MOVING LOADS OF ALL TYPES

SPECIFICATIONS (STD.)

Weight (Double)	49 kg
Weight (Single)	29 kg
WLL	2,000 kg
Proof Load	3,000 kg
O/A Height	215 mm
O/A Width (Single)	510 mm
O/A Width (Double)	970 mm
O/A Length	2020 mm

- TIG welded aluminium construction
- Removable rollers
- CAE refined design
- Low Friction sealed ball races
- Aluminum rollers with steel shafts

DOCUMENTATION

Certificate of Conformity

Load Test Certificate (if specified with order)



BENEFITS

- High Strength, Light Weight
- Easy to transport and carry
- Fits 4-foot
- Single and Double width available



OPTIONS AND ORDERING INFORMATION

Thomson RB11 Roller Beds can be supplied in a plain or a powder coated finish.

Two widths are available: single roller and double roller.

If requested at time of order a load test certificate can be supplied.



Example: RB11-01-01 Single Width Roller Bed in Plain finish

PRODUCT ACCEPTANCE

This product has not been presented for Product Acceptance

MODEL NUMBERS FOR ORDERING

When ordering a RB11 Roller Beds please use the order code below to specify the correct options.

RB11-□□-□□-□

Bed Type	Code
<i>Single Width</i>	01
<i>Double Width</i>	02

Finish	Code
<i>Plain</i>	01
<i>Powder Coated</i>	02

Documentation	Code
<i>Standard</i>	A
<i>+ Load Test Cert.</i>	B

Section 9: Barriers and Access Equipment

9.1 IB13 INSTANT BARRIER SYSTEM



The Thomson Instant Barrier System is the simplest and quickest way to mark out the limits of a work site or to warn of hazards in the rail environment.

The unique rail head clamp simply push fits onto the rail to securely attach the posts to BS113A, CEN60 and Bullhead rail. It is removed just as easily by simply lifting the post.

Single strap, twin strap and rigid rail designs are available as well as a range of accessories including lights and warning lamps.

Stillages containing 100m of barrier can be provided and two stillages fit neatly on a rail trolley.

SPECIFICATIONS

Span per post	0 to 3.6m
Weight (typical per post)	6 kg
Suitability	BS113A CEN 60 Bullhead Rail
Accessories	Red Flashing Light Flood Light Warning Signage Custom Printed Tapes



Steelwork	Bright Zinc Plated
Post	Aluminium Lining Plastic Outer Post

FEATURES

- One Piece Design
- Fitted in Seconds
- Fits most rail types
- Double or single strap design
- Custom printed straps available
- Lamp post option
- Full Factory Parts Backup
- CE Marked

A PUSH-ON, PULL-OFF INSTANT BARRIER SYSTEM FOR MARKING SAFE WORKING AREAS AND HAZARDS

DOCUMENTATION

Operator's Manual
Certificate of Conformity
PADS No. 094/013352



BENEFITS

- Wide variety of options and accessories
- Rapid installation and removal
- Compact design for easy transport



Specifications given may be subject to change due to our policy of continuous improvement

OPTIONS AND ORDERING INFORMATION

The IB13 Instant Barrier System is available as individual posts, stillages with 28 posts or as 18 posts on a specially adapted Elk Trolley Skate (see Page 100).

Each Barrier Post has 3.6m of yellow and black striped tape. Tapes can be printed with logos to special order - please contact the factory for details.

18 posts will produce up to 64m of barrier, 28 posts will produce 100m of barrier.



Example: IB13-02-01 Trolley Skate (available separately as ETS10-03) with 18 Instant Barrier Posts with standard tapes

PRODUCT ACCEPTANCE

This product has full Network Rail Product Acceptance under Certificate Number PA05/06378

MODEL NUMBERS FOR ORDERING

When ordering this product please use the order number below to specify the correct options

IB13-□□-□□

Configuration	Code
Single Barrier Post	01
ETS10-03 Trolley Skate + 18 Posts	02
Stillage + 28 Posts	03

Tapes	Code
Standard Yellow / Black Tapes	01
Special Order Printed Tapes	02



For safely on and off-tracking road rail vehicles without risk of damage to the rail there is no better solution than the Traxess system .

Installed in under twenty minutes the fabricated steel decking can take any vehicle or machine up to 30 tonnes.

Steel tracks or rubber tyres make no difference with Traxess.

Each system comes in a custom made stillage for ease of transport. Loaded stillages can be stacked up to six high for transport or storage.



FEATURES

- Rapid deployment and removal
- Custom designed stackable stillage
- Suits all machines up to 30 tonnes
- Fully tested for durability
- Allows passage of Engineers Trains
- Simple, safe on and off tracking
- Minimal training required
- CE Marked

A TRULY HEAVY-DUTY SOLUTION TO ON AND OFF-TRACKING WHEELED AND TRACKED RRV'S

SPECIFICATIONS

Weight (centre panel)	2000 kg
Weight (side platforms)	970 kg
Weight (total inc. Stillage)	4280 kg
Installation	3 lifts
Deck length	5 m
Height above rail	25 mm

Typical Installation Time	12 mins.
Main Colour	08E51 Yellow
Moving Parts	Signal Red

DOCUMENTATION

- Installation and removal guide
- Factory Test Certificate
- Certificate of Conformity



BENEFITS

- Quick installation and removal
- Simple transportation
- Safe, easy on and off-tracking
- 12mm thick solid steel throughout



Specifications given may be subject to change due to our policy of continuous improvement

OPTIONS AND ORDERING INFORMATION

The Thomson TR13 Traxess Road-Rail Access Platform is available in only one option: as a 5m complete platform with stillage.



PRODUCT ACCEPTANCE

An application was lodged with Network Rail for Product Acceptance in 2013 and was inspected in 2014.

Modifications were made as a result of Network Rail's first inspection and at the time of going to press we await their re-inspection

Example: TR13 Traxess set on stillage

MODEL NUMBERS FOR ORDERING

When ordering this product please use the order number below

TR13

9.3 TAR12 TRACK ACCESS RAMPS



Thompson Track Access Ramps are the solution to getting heavy machines in and out of the dug out track bed without damaging the rail.

The Track Access Ramps incorporate a sleeve which fits over the end of the rail to enclose and protect the rail.

Ramps have a steel treadplate top surface.

Axle loads up to 20 tonnes can be supported by the ramps and full instructions are supplied.

Each Ramp has a lifting point for ease of installation and removal.



FEATURES

- Heavy Duty Design
- Optional Surface
- Single Lifting Point
- Easy to Install and Remove
- Sleeper end panels available for even easier on and off-tracking
- Full Factory Parts Backup
- CE Marked

A SIMPLE WAY TO AVOID DAMAGE TO TYRES AND TO THE RAIL ENDS.

SPECIFICATIONS

Weight (per ramp)	250 kg
Application	BS113A and CEN60
WLL (Max. Axle Load)	20,000 kg
Top	Steel Treadplate
Mechanism	Loose Hinge

Finish 08E51 Yellow

DOCUMENTATION

Operator's / Maintenance Manual
Quick start Installation Guide



BENEFITS

- Protects both rail and machine
- Reduced tyre damage
- Purpose designed system



OPTIONS AND ORDERING INFORMATION

Thomson TAR12 Track Access Ramps are available in pairs.

A transport / storage stillage for one pair of TAR12 Track Access Ramps is also available



PRODUCT ACCEPTANCE

No application has been made for Network Rail Product Acceptance to date

Example: TAR12-01 One Pair of Track Access Ramps with no stillage

MODEL NUMBERS FOR ORDERING

When ordering this product please use the order number below to specify the correct options

TAR12-□□

Configuration	Code
One Pair of Ramps	01
Pair of Ramps with Stillage	02

Section 10: Adapter Heads

Important Note When Specifying Adapters

Hinged Connection

When specifying an adapter system for any lifting attachment equipped with a bolted flange adapter mount it is very important to ensure that the system chosen allows the attachment to swing freely to align with the load.

Our two-pin and one-pin rotator adapters incorporate hinges at 90 degrees to each other to allow the attachment to swing around the machine boom end pin and the rotator top pin to give the attachment complete freedom of movement.

Without this feature the flange will become overloaded unless the load is perfectly balanced and this can lead to failure of the flange bolts and the catastrophic failure of the attachment.

Free Rotation

When using a hydraulic rotator it is also important to ensure that a suitable pressure relief system is installed to prevent shock loading: for example, when an operator is rotating a load and suddenly releases the control, the momentum of the load can cause extremely high shock loads if no relief system is fitted.

Hydraulic Rotators fitted to our attachments have a small bore cross line connection installed between the hoses on the rotate circuit to dampen out shock loads.



Rotator hoses are connected together using a small bore fitting to dampen out shock loadings

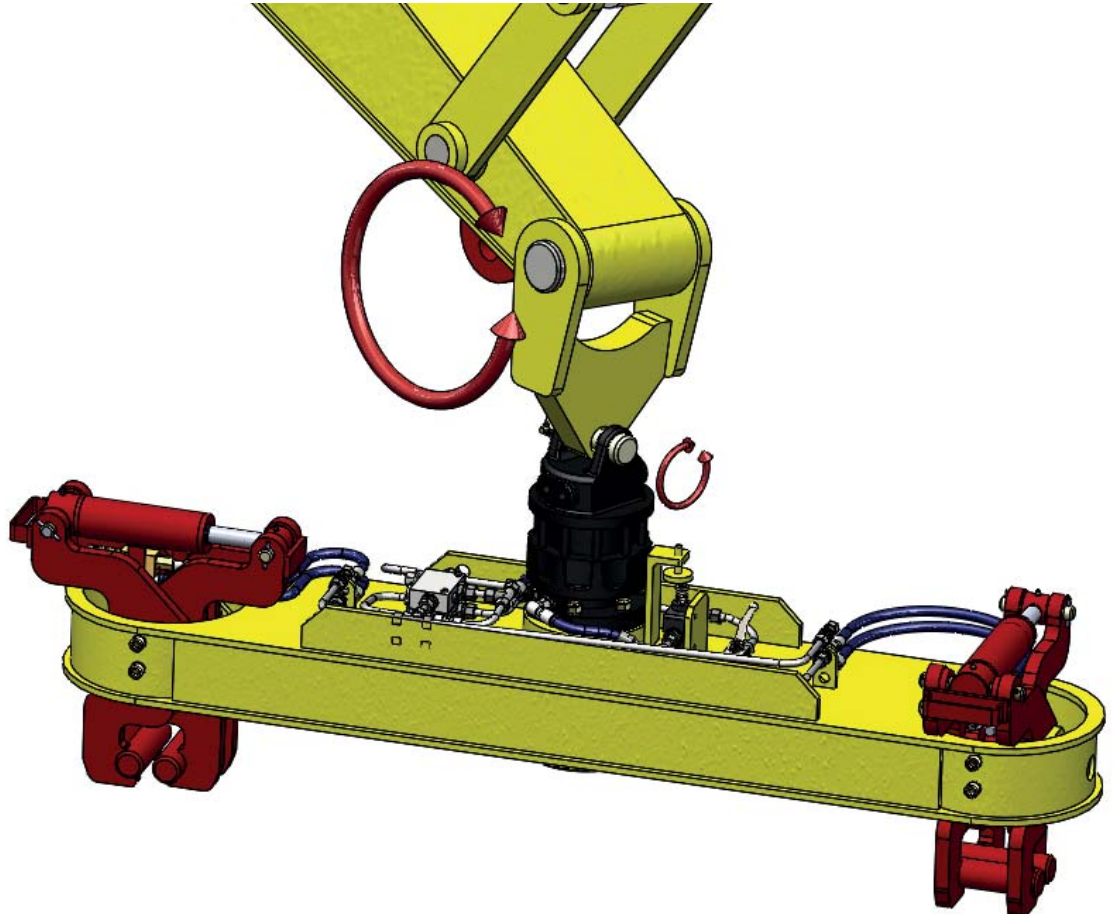

Two Hinges at 90 degrees to each other allow the attachment to swing freely and prevent the bolted flange becoming overloaded.

Quick Change System for Truck Cranes

The versatility of truck mounted cranes, such as the Hiab or Pesci units, may be significantly enhanced by the use of attachments but the cost of each attachment can be difficult to justify.

By using the Thomson Quick change system a single rotator is permanently attached to the crane boom and a quick change square drive adapter is fitted to each attachment. This saves the cost of a separate rotator and adapter head for each attachment and speeds up the swapping of attachments.

The Thomson Quick Change system is available with a variety of weight capacities and adapter heads.

Please contact us for further information.



Heads for Hooks

Where a beam or grab is to be lifted by a crane a head with built-in shackle is required.

Please refer to the note on page 121 when specifying this type of adapter.

Type 01

Fixed Adapter Head for use with swivel hooks

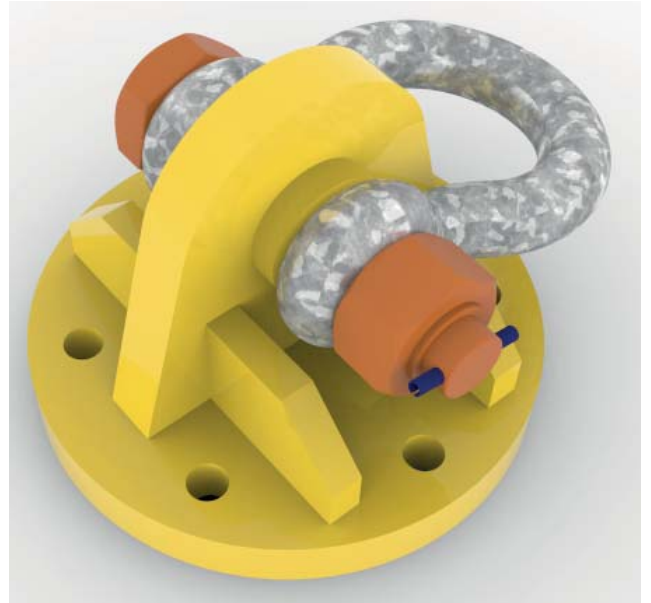

Type 02

Swivel Adapter Head for use with fixed or rotating (unladen only) hooks



Important Note about Heads for Hooks

Three broad classes of hook are used on cranes and lifting machines: *Swivel Hooks which have a bearing built into the hook assembly allowing the load to spin freely, Rotating Hooks which can be spun only when unloaded and Fixed Hooks which do not spin at all.*

It is important to check which type of hook is fitted to your machine as damage may occur if a fixed adapter head is used with a fixed or rotating hook.

Fixed or Rotating (unladen only) Hooks

A Swivel Head Adapter **MUST** be specified with this type of hook. The swivel head incorporates bearings to allow the load to spin and reduce the stress applied to the attachment, the hook and the host machine.

Swivel Head Adapters are factory-fitted with a safety pin bow shackle for attachment to the hook. They bolt directly to the 6-bolt flange on the lifting device.

Swivel Hooks

Where Swivel Hooks are fitted to the host machine the most popular system is the Low Headroom Attachment Head.

This adapter also incorporates a safety pin bow shackle for attaching to the hook but it is rigidly fixed to the beam or grab.



A typical Swivel Head Adapter



Low Headroom Attachment Head

One-Pin Rotator Heads for Direct Mounting

Where the beam, grab or attachment has a rotator and is to be fitted to an excavator which does not have a quick coupler a One-Pin Adapter Head should be specified.

This arrangement is as shown below. The Main Pin (1) is removable and fits through the excavator boom end boss.

When specifying this attachment system we need to know the two dimensions shown on page 123.



Rotator and One-Pin Adapter Head

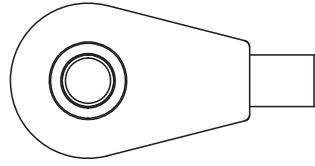
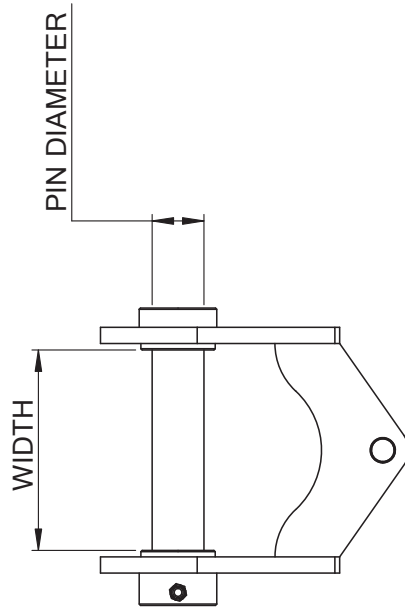
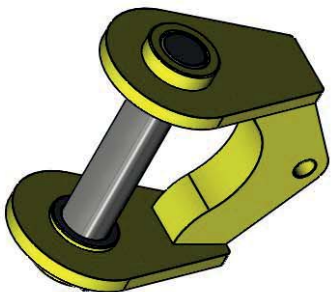
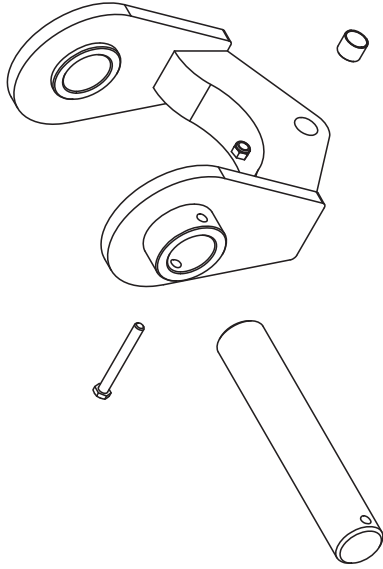

PIN DIAMETER.....mm

WIDTH.....mm

Two-Pin Heads for Quick Couplers

Where the beam, grab or attachment has a rotator and is to be fitted to an excavator with a pin type quick coupler a Two-Pin Attachment Head is required.

This arrangement is as shown below. The Two-Pin Attachment Head can pivot about the rotator top pin (1) and the rear attachment pin (2) so that the grab always hangs freely below the quick coupler.

When specifying this attachment system we need to know the three dimensions as shown on page 125.

Two pin heads for machines, as shown below left for example, require the same dimensions to be specified.



A typical pin type Quick Coupler

Type 04

Rotator and two-pin adapter head

Note that the dimensions on page 125 must be given when ordering.

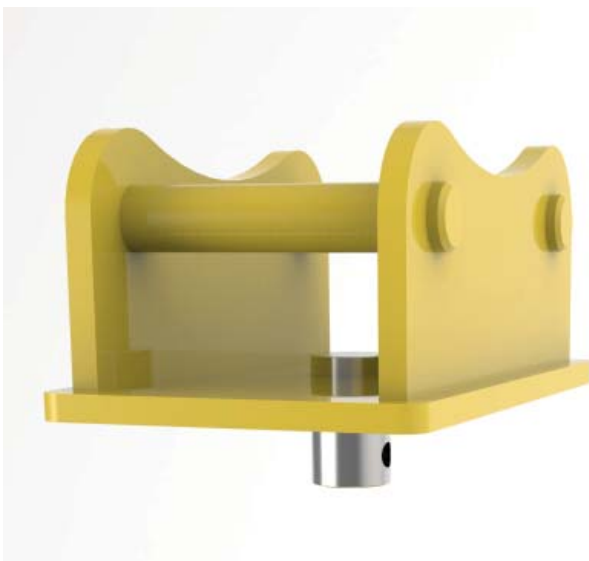

Typical Two-Pin Machine Adapter Head



Rotator and Two-Pin Adapter Head

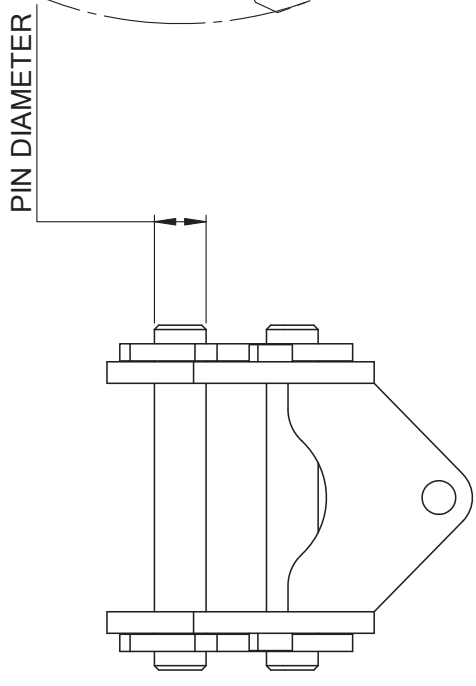
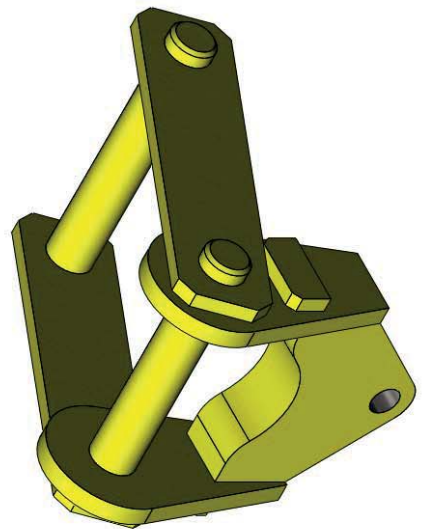
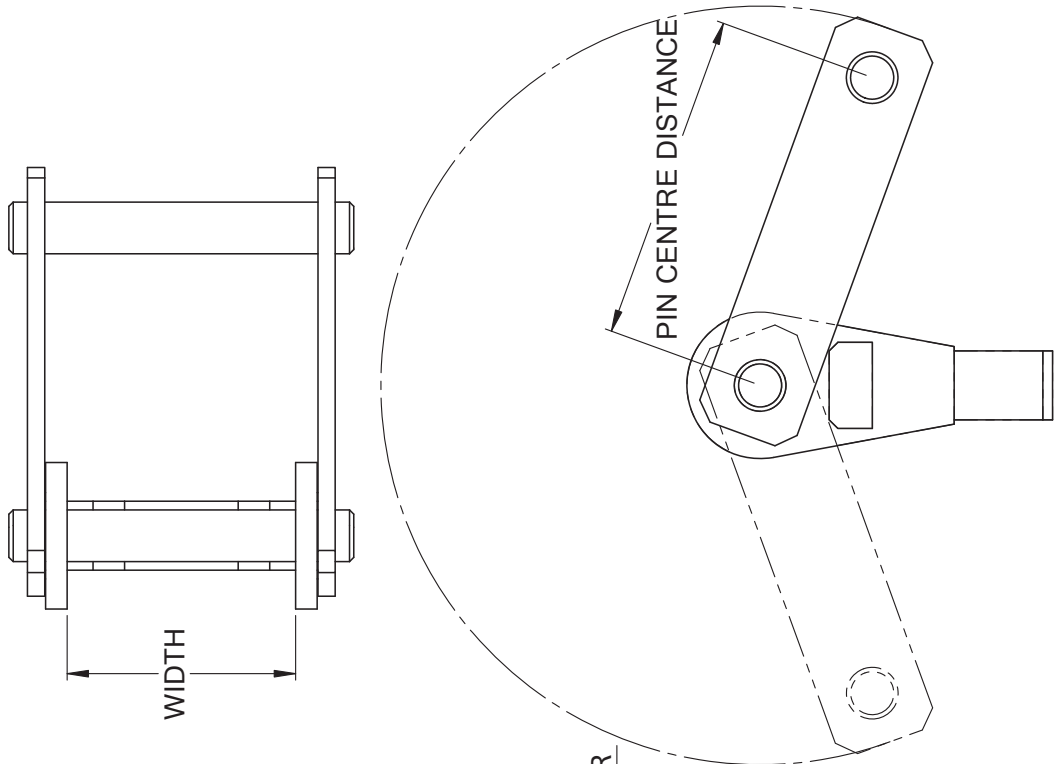

PIN DIAMETER.....mm WIDTH.....mm PIN CENTRE DISTANCE.....mm

Archimedes Adapter Heads

Where the beam, grab or attachment is to be fitted to an excavator equipped with an Archimedes Rotator an Archimedes Adapter must be specified.

A typical Archimedes Adapter Head is shown below. The square recess engages with the square drive-shaft of the Archimedes rotator and is fixed with a cross pin (not shown).

When specifying this attachment system we need to know the SIX dimensions shown on Page 127.

IMPORTANT NOTE

All attachments equipped with 6-bolt flange attachment points must be fitted with free-hinged adapters

Type 05

Archimedes / Truck Quick Change adapter head

Note that the dimensions on page 127 must be given when ordering for fitment to existing plant.

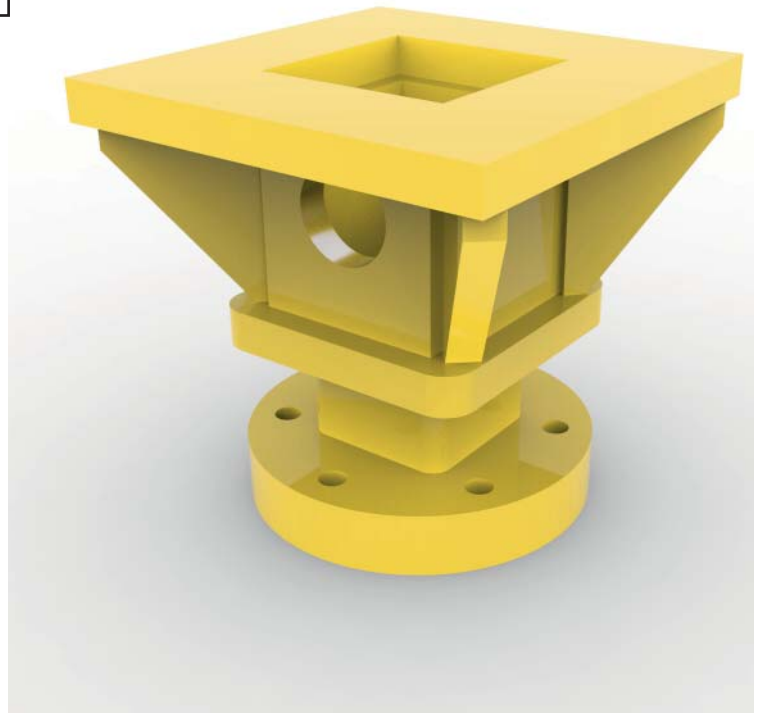

A typical Atlas Square Drive Adapter Head

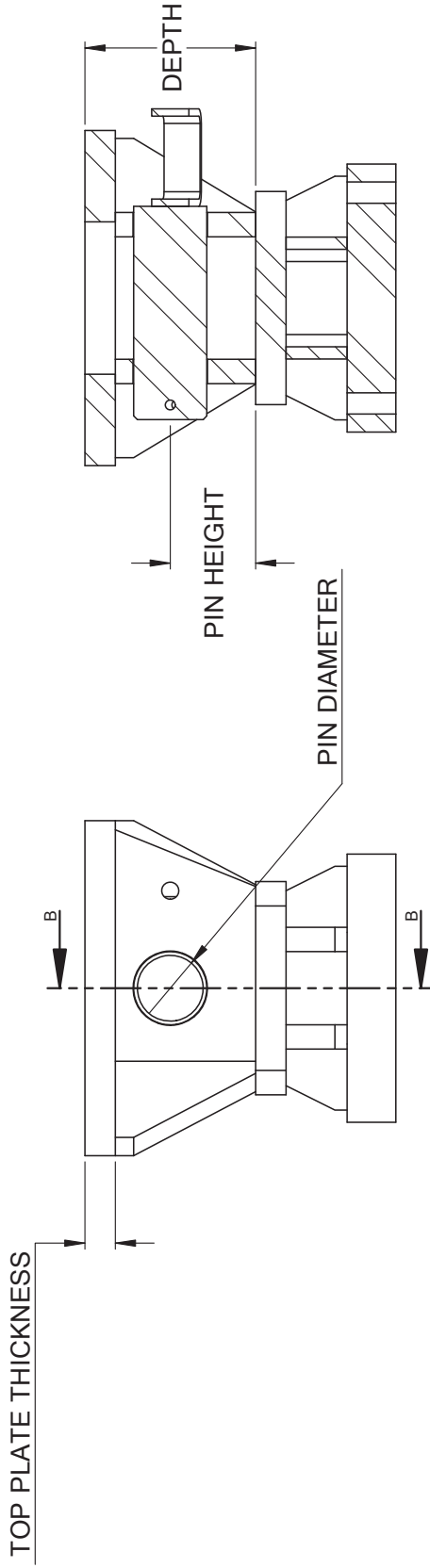
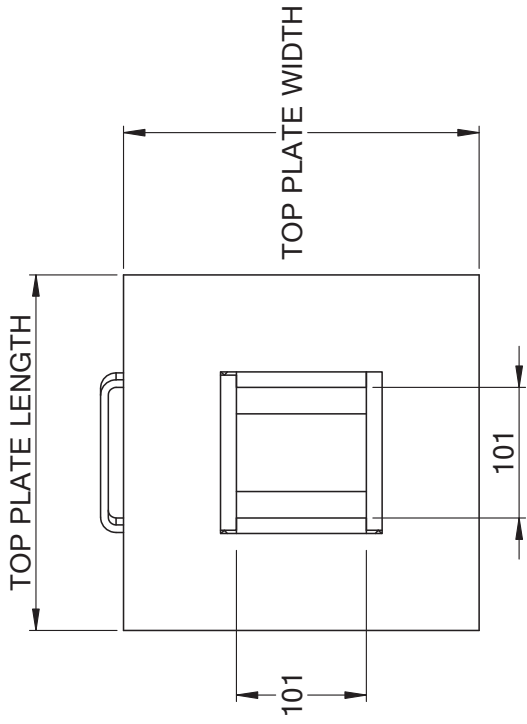
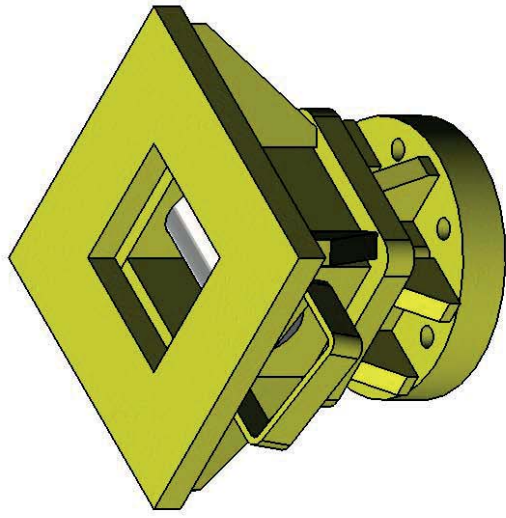

PIN DIAMETER.....mm PIN HEIGHT.....mm DEPTH.....mm TOP PLATE LENGTH.....mm

TOP PLATE WIDTH.....mm TOP PLATE THICKNESS.....mm

Adapter Heads for Truck Mounted Cranes

Where the beam, grab or attachment is to be fitted to a truck mounted crane the crane mounting will normally take the form shown below and will require an adapter link as shown in the illustration below.

When specifying this attachment system we need to know the FOUR dimensions shown on Page 129.

Please also note that we can supply plain pins or pins with grease ways as required.

Type 06

Rotator and truck crane adapter head

Note that the dimensions on page 129 must be given when ordering.



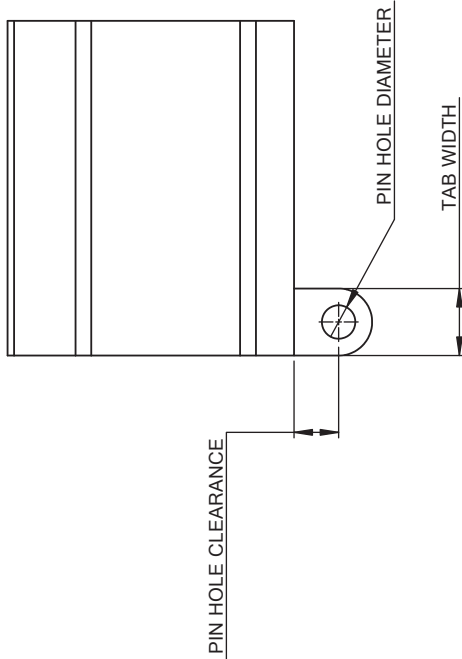
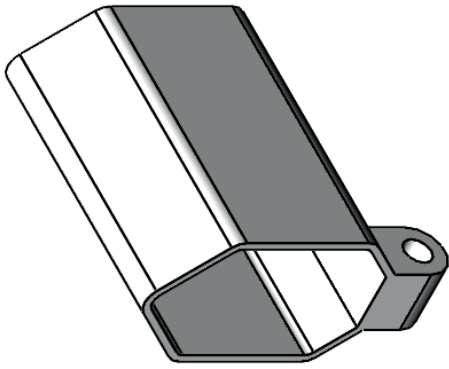
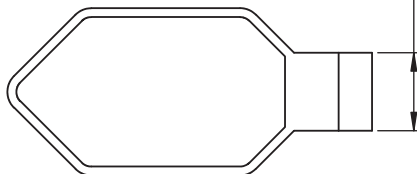
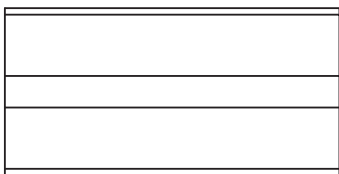

PIN HOLE DIAMETER.....PIN HOLE CLEARANCE.....TAB WIDTH.....MAX TAB THICKNESS

Special Adapter Heads

Thomson Engineering Design produce a wide variety of custom adapter heads for all applications including those shown on page 131 as well as many others.

For further details please contact the factory.

IMPORTANT NOTE

All attachments equipped with 6-bolt flange attachment points must be fitted with free-hinged adapters

Type 07

Special adapter heads

Please contact the factory before ordering to check the availability of particular types.



Caterpillar CW40



Atlas / Pesci / Hiab Truck
Crane



Atlas Excavator



Swivel Converter



Quick Coupler Converter

About Unipart

The Unipart Group is a leading UK manufacturer, full service logistics provider and consultant in operational excellence.

Operating across a range of market sectors, including automotive, manufacturing, mobile telecoms, rail, retail and technology, Unipart offers a breadth of services to a wide range of blue chip clients internationally.

About Thomson Engineering Design

Thomson Engineering Design has been manufacturing specialised equipment for rail renewals and repairs since 1999 and in that time have become the premier supplier of attachments for Road Rail Vehicles.

Offering a range of over 100 products for all rail maintenance sectors and activities, Thomson are a key supplier for all rail plant companies in the UK.



Unipart Rail are the export distribution partner for Thomson Engineering Design, for enquiries please contact railplant@unipartrail.com

Unipart Rail

Jupiter Building, First Point, Balby Carr Bank,
Doncaster DN4 5JQ

Tel: +44 (0) 1302 731400

email: enquiries@unipartrail.com



Visit www.unipartrail.com for details
of our Worldwide Regional Offices